

GROUP 14

ENGINE COOLING**CONTENTS**

GENERAL DESCRIPTION	14-2	RADIATOR	14-23
SPECIAL TOOLS	14-3	REMOVAL AND INSTALLATION	14-23
ENGINE COOLING DIAGNOSIS	14-3	THERMOSTAT	14-25
INTRODUCTION.....	14-3	REMOVAL AND INSTALLATION	14-25
TROUBLESHOOTING STRATEGY	14-3	INSPECTION.....	14-27
SYMPTOM CHART.....	14-4	WATER PUMP	14-28
SYMPTOM PROCEDURES	14-4	REMOVAL AND INSTALLATION	14-28
ON-VEHICLE SERVICE	14-18	WATER HOSE AND WATER PIPE ..	14-30
ENGINE COOLANT LEAK CHECK	14-18	REMOVAL AND INSTALLATION	14-30
RADIATOR CAP PRESSURE CHECK....	14-18	INSPECTION.....	14-33
ENGINE COOLANT REPLACEMENT	14-19	SPECIFICATIONS	14-34
ENGINE COOLANT CONCENTRATION TEST.....	14-20	FASTENER TIGHTENING SPECIFICATIONS.....	14-34
FAN CONTROL MODULE CHECK	14-20	SERVICE SPECIFICATIONS	14-35
FAN CONTROL RELAY CONTINUITY CHECK	14-21	COOLANT	14-35
COOLING FAN MOTOR CHECK.....	14-22	SEALANTS	14-35

GENERAL DESCRIPTION

M1141000100337

The cooling system is designed to keep every part of the engine at appropriate temperature in whatever condition the engine may be operated. The cooling method is of the water-cooled, pressure forced circulation type in which the water pump pressurizes coolant and circulates it throughout the engine. If the engine coolant temperature exceeds the prescribed temperature, the thermostat opens to circulate the coolant through the radiator as well so that the heat absorbed by the coolant may be radiated into the air. The water pump is of the centrifugal type and is driven by the drive belt from the crankshaft. The radiator is the corrugated fin, down flow type. The cooling fan is controlled by the fan control module and engine control module depend on driving conditions.



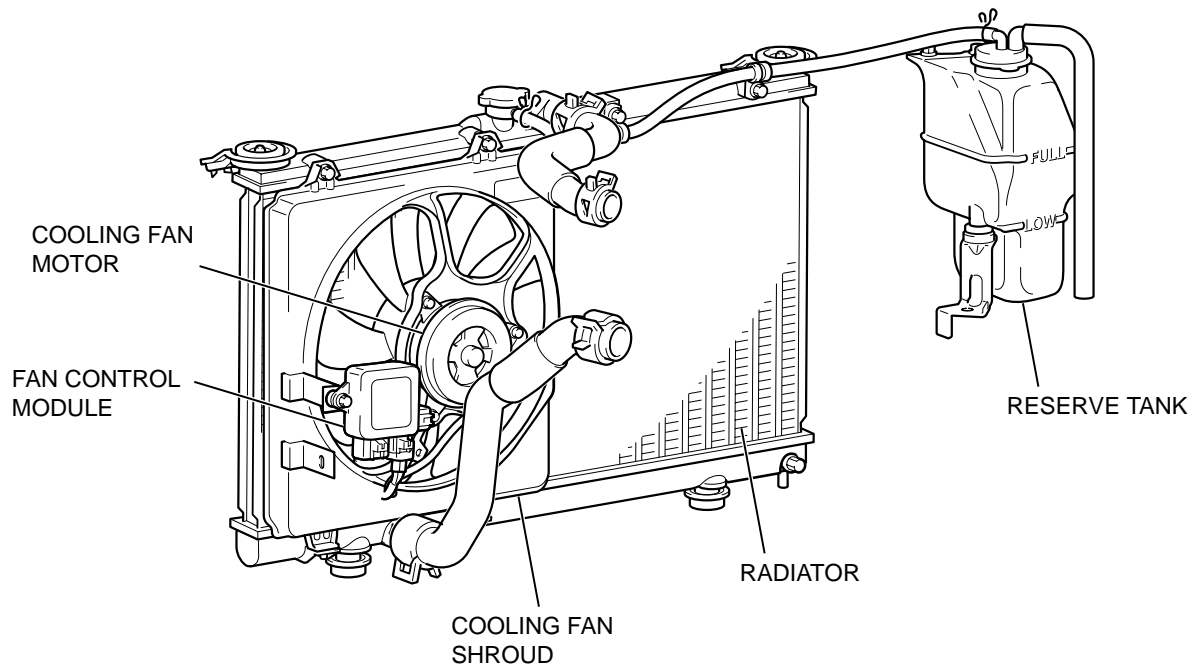

CONSTRUCTION DIAGRAM

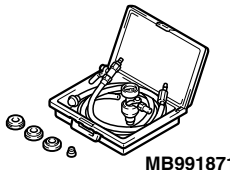

AC210269 AB

SPECIAL TOOLS

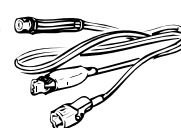
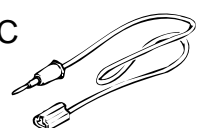
M114100600202

TOOL	TOOL NUMBER AND NAME	SUPERSSION	APPLICATION
 <p>MB991871</p>	<p>MB991871 LLC changer</p>	<p>General service tool</p>	<p>Coolant refilling</p>
<p>A</p>  <p>B</p>  <p>C</p>  <p>D</p>  <p>MB991223AG</p>	<p>MB991223 A: MB991219 B: MB991220 C: MB991221 D: MB991222 Harness set A: Test harness B: LED harness C: LED harness adapter D: Probe</p>	<p>General service tools</p>	<p>Making voltage and resistance measurement during troubleshooting A: Connector pin contact pressure inspection B: Power circuit inspection C: Power circuit inspection D: Commercial tester connection</p>

ENGINE COOLING DIAGNOSIS

INTRODUCTION

M1141005300314

The system cools the engine so that it does not over-heat and maintains the engine at an optimum temperature. The system components are the radiator, water pump, thermostat, cooling fan. Possible faults include low coolant, contamination, belt loosening and component damage.

TROUBLESHOOTING STRATEGY

M1141005200317

Use these steps to plan your diagnostic strategy. If you follow them carefully, you will be sure to find most of the engine cooling faults.

1. Gather information from the customer.

2. Verify that the condition described by the customer exists.
3. Find and repair the malfunction by following the SYMPTOM CHART.
4. Verify that the malfunction is eliminated.

SYMPTOM CHART

SYMPTOM	INSPECTION PROCEDURE	REFERENCE PAGE
Coolant Leak	1	P.14-4
Engine Overheating	2	P.14-5
Cooling Fan Does Not Operate	3	P.14-6
Cooling Fan Does Not Change Speed or Does Not Stop	4	P.14-14

SYMPTOM PROCEDURES

INSPECTION PROCEDURE 1: Coolant Leak

DIAGNOSIS

STEP 1. Check for coolant leaks.

⚠ WARNING

When pressure testing the cooling system, slowly release cooling system pressure to avoid getting burned by hot coolant.

⚠ CAUTION

- Be sure to completely clean away any moisture from the places checked.
- When the tester is removed, be careful not to spill any coolant.
- When installing and removing the tester and when testing, be careful not to deform the filler neck of the radiator.

Check that the coolant level is up to the filler neck. Install a radiator tester and apply 160 kPa (23 psi) pressure, and then check for leakage from the radiator hose or connections.

Q: Is leakage present from the radiator hose or connections?

YES : Repair or replace the appropriate part, then go to Step 2.

NO : There is no action to be taken.

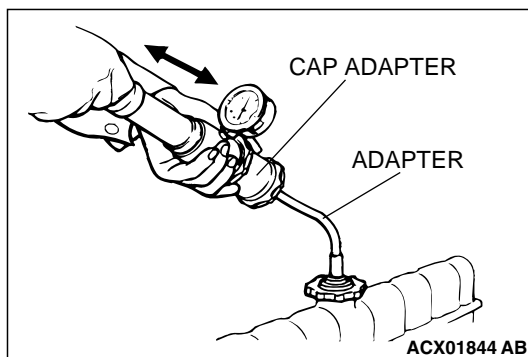

STEP 2. Retest the system.

Q: It there still coolant leakage?

YES : Return to Step 1.

NO : The procedure is complete.

INSPECTION PROCEDURE 2: Engine Overheating

DIAGNOSIS

STEP 1. Remove the radiator cap and check for coolant contamination.

Q: Is the coolant contaminated with rust and oil?

YES : Replace it. Refer to [P.14-19](#).

NO : There is no action to be taken. Go to Step 2.

STEP 2. Check the radiator cap valve opening pressure.

NOTE: Be sure that the cap is clean before testing. Rust or other foreign material on the cap seal will cause an improper reading.

- (1) Use a cap adapter to attach the cap to the tester.
- (2) Increase the pressure until the gauge indicator stops moving.

Minimum limit: 83 kPa (12 psi)

Standard value: 93 – 123 kPa (14 – 18 psi)

Q: Does the reading remain at or above the minimum limit?

YES : Go to Step 3.

NO : Replace the radiator cap. Then go to Step 5.

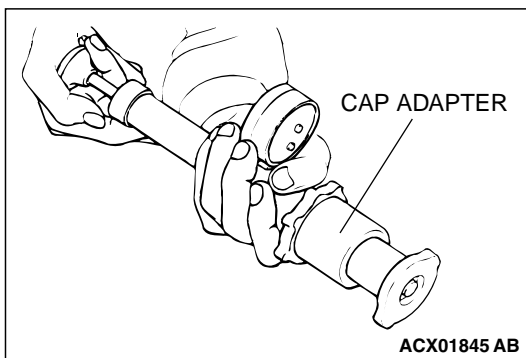

STEP 3. Check thermostat operation.

Refer to [P.14-27](#).

Q: Does the thermostat operate correctly?

YES : Go to Step 4.

NO : Replace the thermostat, then go to Step 5.

STEP 4. Check the drive belt for slippage or damage.

Refer to GROUP 00, Maintenance Service – Drive Belts (Check Condition) [P.00-46](#).

Q: Is the drive belt loose or damaged?

YES : Replace the drive belt, then go to Step 5.

NO : There is no action to be taken.

STEP 5. Retest the system.

Check the engine coolant temperature.

Q: Is the engine coolant temperature abnormally high?

YES : Return to Step 2.

NO : The procedure is complete.

INSPECTION PROCEDURE 3: Cooling Fan Does Not Operate

Cooling Fan Drive Circuit

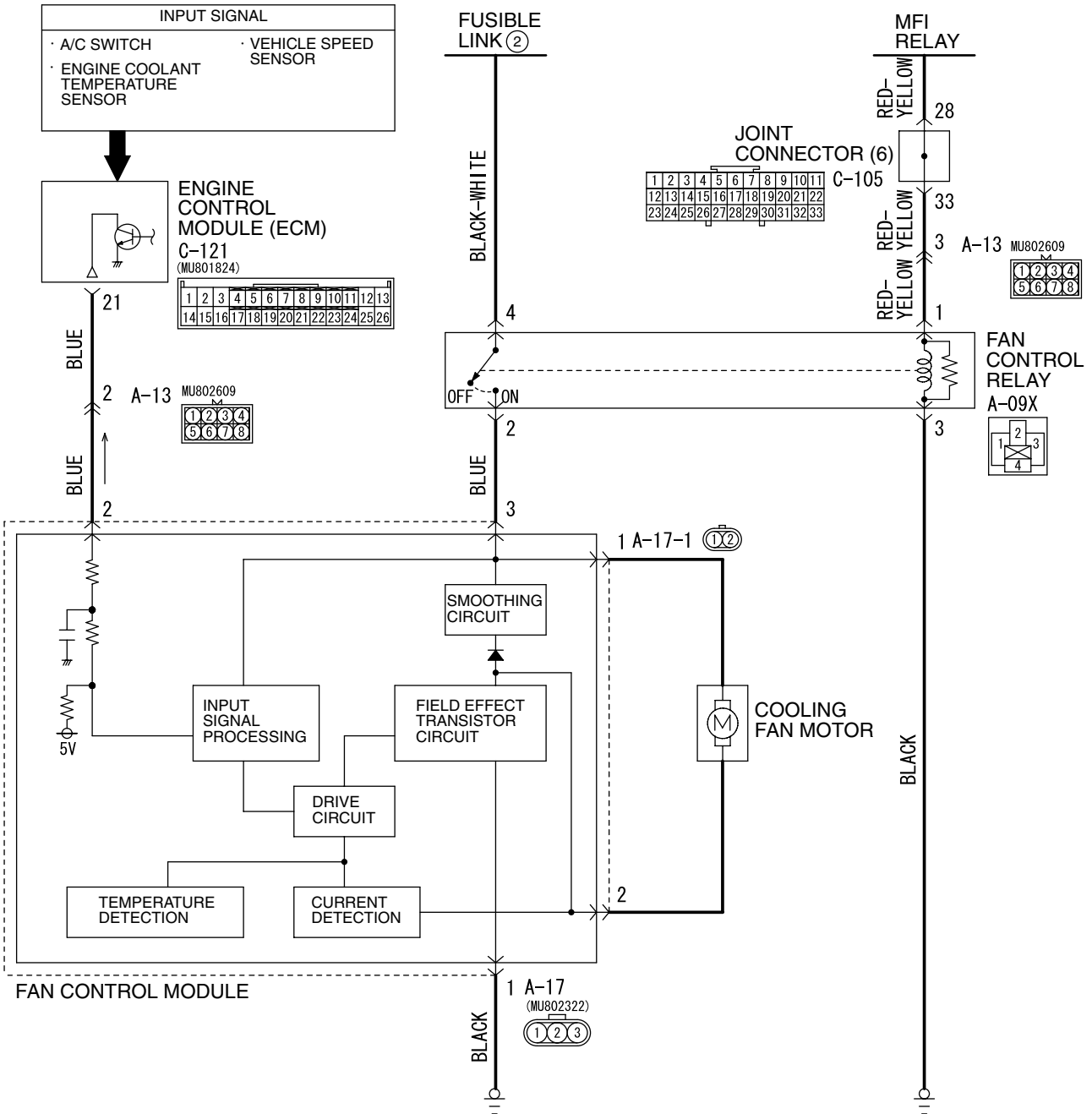

W3J12M01AA
AC210678AB

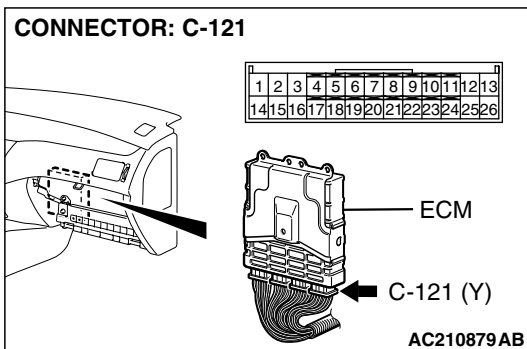
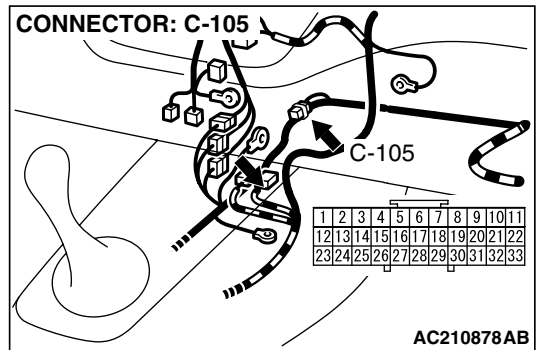
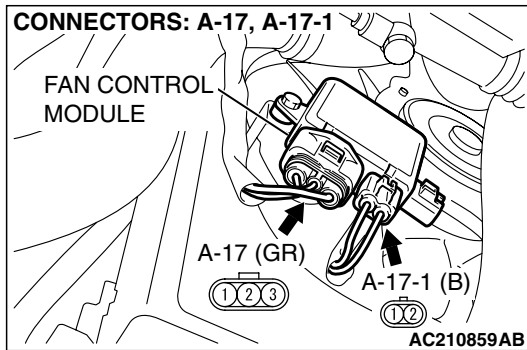
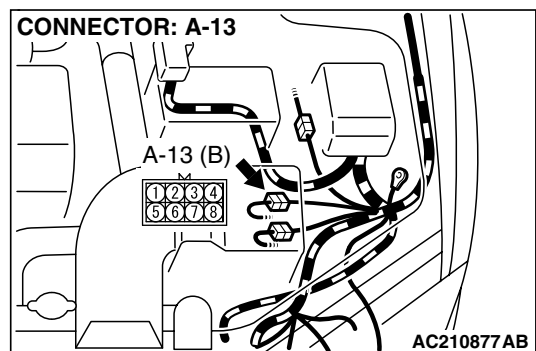
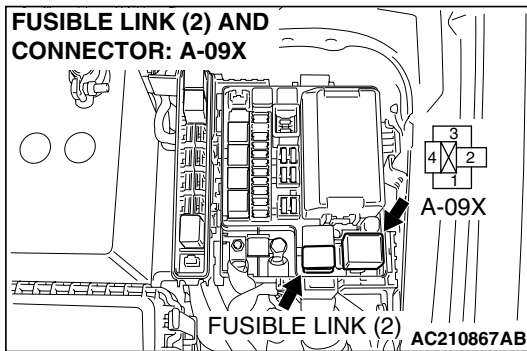

CIRCUIT OPERATION

- The fan control module is powered from fusible link number 2.
- The engine control module (ECM) judges the required revolution speed of cooling fan motor using the input signals transmitted from A/C switch, vehicle speed sensor and engine coolant temperature sensor. The ECM activates the fan control module to drive the cooling fan motor.

TECHNICAL DESCRIPTION

- The cause could be a malfunction of the fan control module power supply or ground circuit.
- The cause could also be a malfunction of the fan control module or the ECM.

TROUBLESHOOTING HINTS

- Malfunction of fusible link
- Malfunction of fan control relay
- Malfunction of cooling fan motor
- Malfunction of fan control module
- Malfunction of ECM
- Damaged wiring harness or connector

DIAGNOSIS

Required Special Tool:

- MB991223: Harness Set

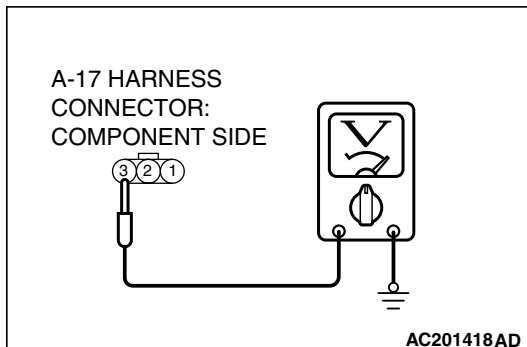
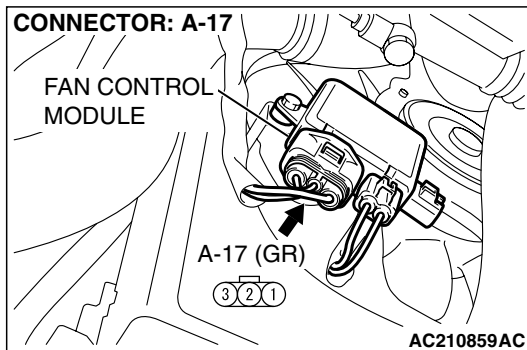

STEP 1. Check the circuit at fan control module connector A-17 terminal 3.

- (1) Disconnect fan control module connector A-17, and measure at the harness side connector.
- (2) Measure the voltage between terminal number 3 and ground.
 - When the ignition switch is turned to the "ON" position, voltage should measure battery positive voltage.

Q: Is the voltage battery positive voltage when the ignition switch is turned to the "ON" position?

YES : Go to Step 7.

NO : Go to Step 2.

STEP 2. Check the fan control relay.

Refer to [P.14-21](#).

Q: Is the fan control relay in good condition?

YES : Go to Step 3.

NO : Replace it, then go to Step 1.

STEP 3. Check for harness damage between fusible link number 2 and fan control relay connector A-09X terminal 4.

Q: Are the harness wires between fusible link number 2 and fan control relay connector A-09X damaged?

YES : Repair or replace them, then go to Step 13.

NO : Go to Step 4.

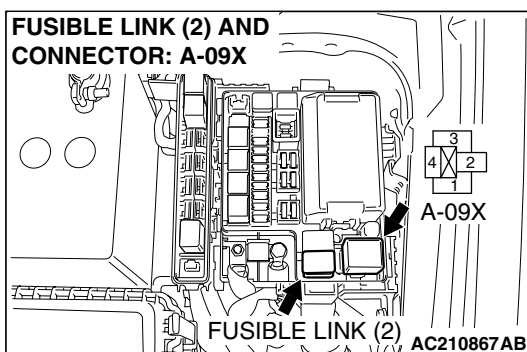

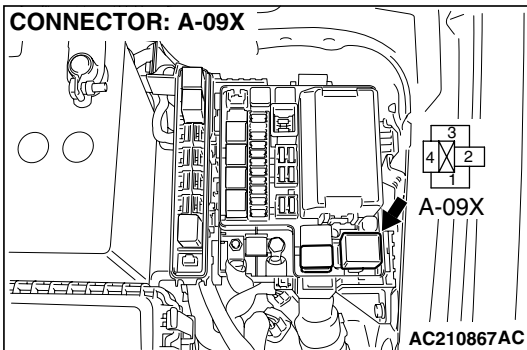

STEP 4. Check for harness damage between fan control relay connector A-09X terminal 2 and fan control module connector A-17 terminal 3.

Q: Are the harness wires between fan control relay connector A-09X terminal 2 and fan control module connector A-17 terminal 3 damaged?

YES : Repair or replace them, then go to Step 13.

NO : Go to Step 5.

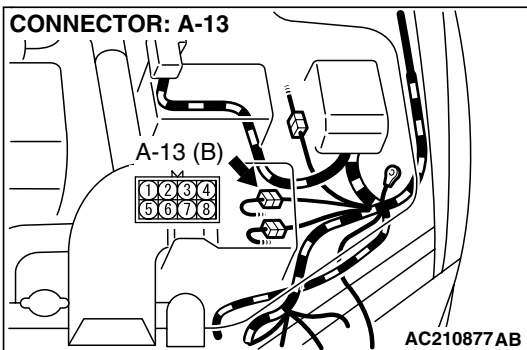
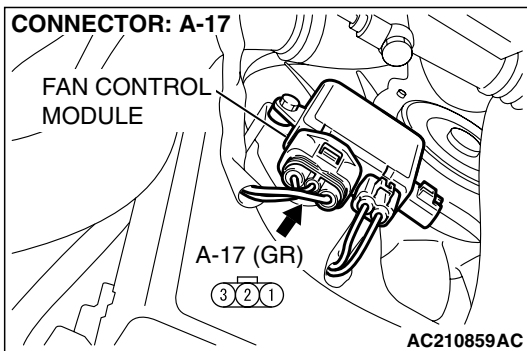

STEP 5. Check for harness damage between joint connector (6) C-105 and fan control relay connector A-09X.

NOTE: After inspecting intermediate connector A-13 terminal 3 and joint connector (6) C-105 terminal 28, 33 inspect the wires. If intermediate connector A-13 and joint connector (6) C-105 are damaged, repair or replace them. Refer to GROUP 00E, Harness Connector Inspection [P.00E-2](#).

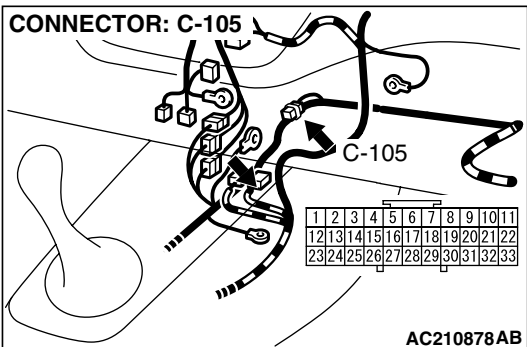

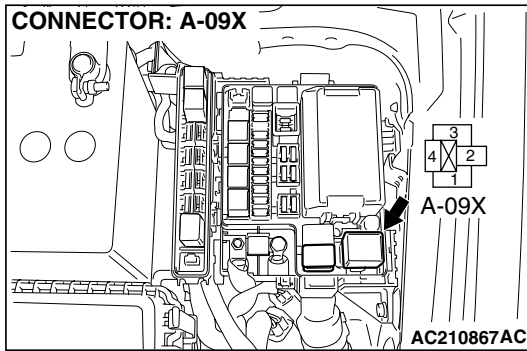

Q: Are the harness wires between joint connector (6) C-105 terminal 28 and fan control relay connector A-09X terminal 1 damaged?

YES : Repair or replace them, then go to Step 13.

NO : Go to Step 6.

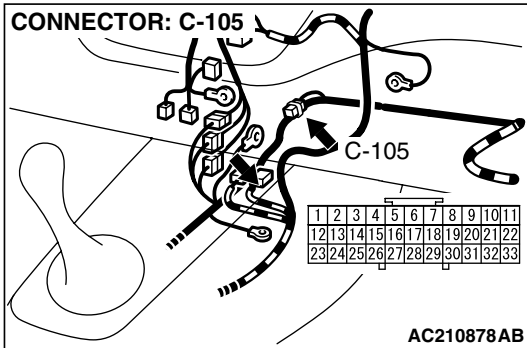

STEP 6. Check for harness damage between fan control relay connector A-09X terminal 3 and ground.

Q: Are the harness wires between fan control relay connector A-09X terminal 3 and ground damaged?

YES : Repair or replace them, then go to Step 13.

NO : Go to Step 7.

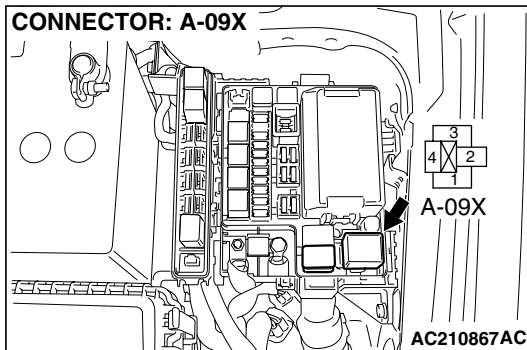

STEP 7. Check the cooling fan motor.

Refer to [P.14-22](#).

Q: Is the cooling fan motor in good condition?

YES : Go to Step 8.

NO : Replace it, then go to Step 13.

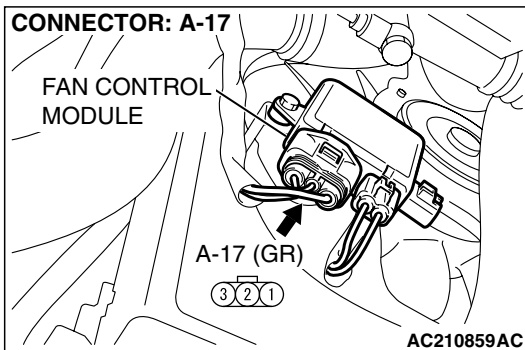

STEP 8. Check the circuit at fan control module connector A-17 terminal 1.

- (1) Disconnect fan control module connector A-17, and measure at the harness side connector.
- (2) Measure the resistance between terminal number 1 and ground.
 - The resistance should measure less than 2 ohms.

Q: Is the resistance less than 2 ohms?

YES : Go to Step 10.

NO : Go to Step 9.

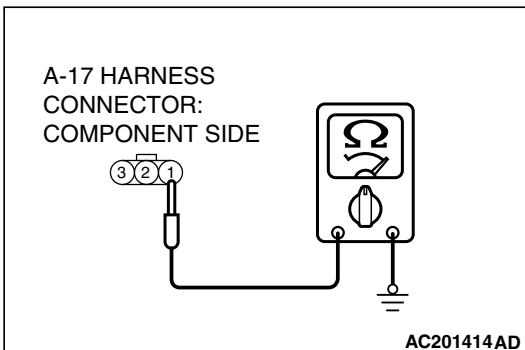

STEP 9. Check the harness wire between fan control module connector A-17 and ground.

Q: Are the harness wires between fan control module connector A-17 and ground damaged?

YES : Repair or replace them, then go to Step 13.

NO : Go to Step 10.

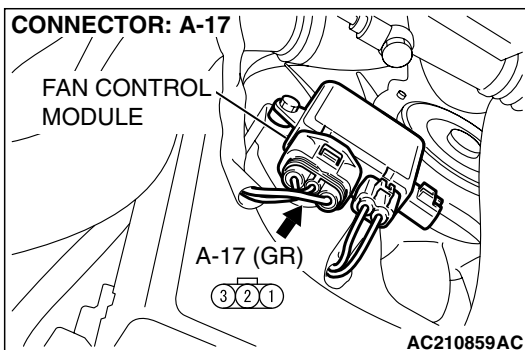

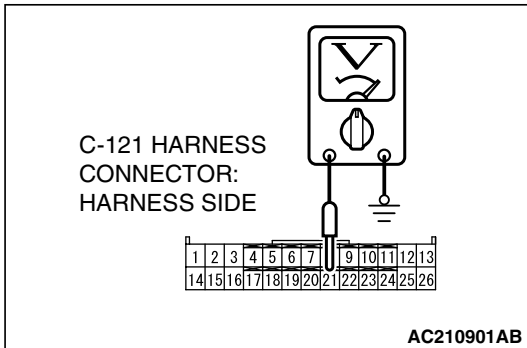
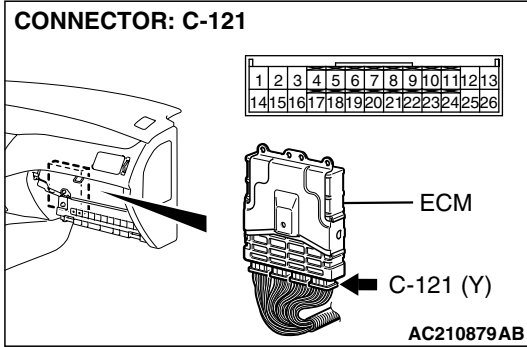

STEP 10. Measure the output circuit voltage at ECM connector C-121 terminal 21 by backprobing.

- (1) Do not disconnect ECM connector C-121.
- (2) Start the engine and allow it to idle.
- (3) Turn the A/C switch to the "ON" position.
- (4) Measure the voltage between terminal number 21 and ground by backprobing.
 - The voltage should measure 0.7 volt or more when the cooling fan is operating.

Q: Is the voltage 0.7 volt or more when the cooling fan is operating?

YES : Go to Step 12.

NO : Go to Step 11.

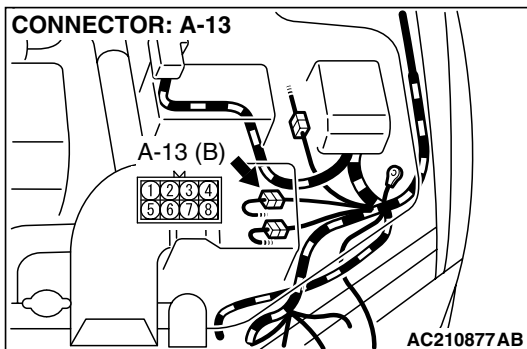

STEP 11. Check the harness wire between ECM connector C-121 and fan control module connector A-17.

NOTE: If intermediate connector A-13 terminal 2 is damaged, repair or replace it. Refer to GROUP 00E, Harness Connector Inspection P.00E-2.

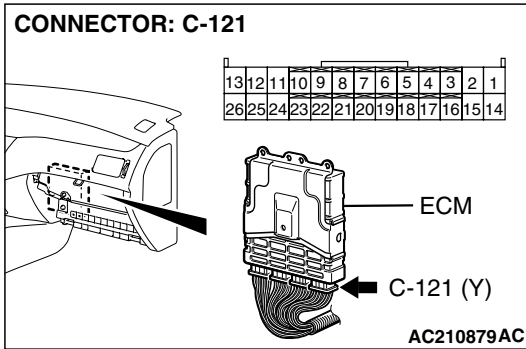

Q: Are the harness wires between ECM connector C-121 terminal 21 and fan control module connector A-17 terminal 2 damaged?

YES : Repair or replace them, then go to Step 13.

NO : Go to Step 12.

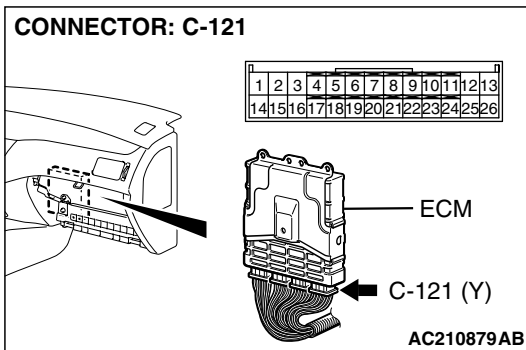
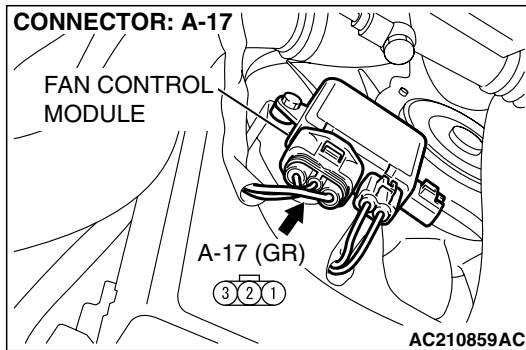

STEP 12. Check the fan control module at ECM connector C-121.

- (1) Do not disconnect ECM connector C-121.
- (2) Pull out terminal number 21.
- (3) Turn the ignition switch to the "ON" position.

Q: Does the cooling fan motor operate?

YES : Replace the ECM. Then go to Step 13.

NO : Replace the fan control module. Then go to Step 13.

STEP 13. Check the symptoms.

Q: Does the cooling fan operate correctly?

YES : The procedure is complete.

NO : Return to Step 1.

INSPECTION PROCEDURE 4: Cooling Fan Does Not Change Speed or Does Not Stop

NOTE: If the engine coolant temperature reaches 110°C (230°F) or higher, the cooling fan control runs the cooling fan for up to 5 minutes even after the ignition switch is turned to the "LOCK" (OFF) position [the fan stops its rotation when the engine coolant temperature decreases to 110°C (230°F) or lower.]

Cooling Fan Drive Circuit

Refer to [P.14-6](#).

CIRCUIT OPERATION

- The fan control module is powered from fusible link number 2.
- The ECM judges the required revolution speed of cooling fan motor using the input signals transmitted from A/C switch, vehicle speed sensor and engine coolant temperature sensor. The ECM activates the fan control module to drive the cooling fan motor.

TECHNICAL DESCRIPTION

- The fan control module has variable control of the cooling fan motor speed using signals transmitted from the ECM.

TROUBLESHOOTING HINTS

- Malfunction of fan control relay
- Malfunction of fan control module
- Malfunction of ECM

DIAGNOSIS**Required Special Tool:**

- MB991223: Harness Set

STEP 1. Check the fan control relay.

Refer to [P.14-21](#).

Q: Is the fan control relay in good condition?

YES : Go to Step 2.

NO : Replace the part, then go to Step 8.

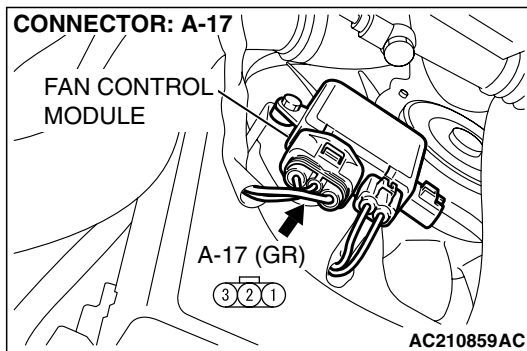
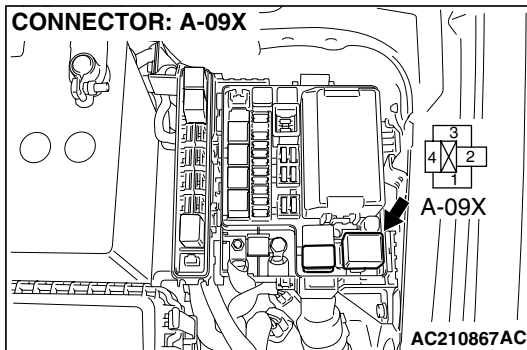

STEP 2. Check the harness wire between fan control relay connector A-09X terminal 2 and fan control module connector A-17 terminal 3.

Q: Are the harness wire between fan control relay connector A-09X and fan control module connector A-17 damaged?

YES : Repair or replace the part, then go to Step 6.

NO : Go to Step 3.

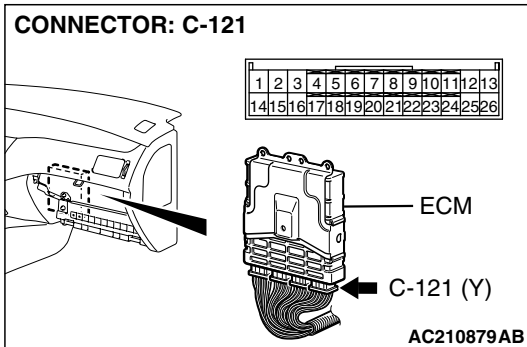

STEP 3. Measure the output circuit voltage at ECM connector C-121 terminal 21 by backprobing.

(1) Do not disconnect ECM connector C-121.

(2) Start the engine and allow it to idle.

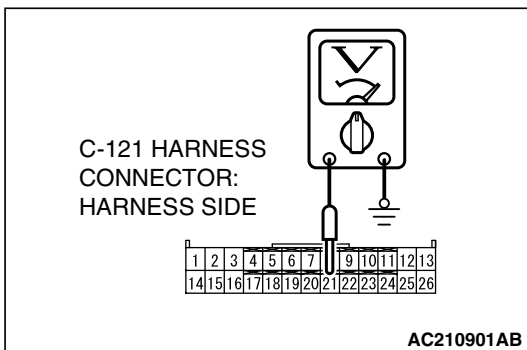

(3) Measure the voltage between terminal number 21 and ground by backprobing.

- The voltage should measure less than 0.3 volt when the cooling fan is not operating.

Q: Is the voltage less than 0.3 volt when the cooling fan is not operating?

YES : Go to Step 6.

NO : Go to Step 4.

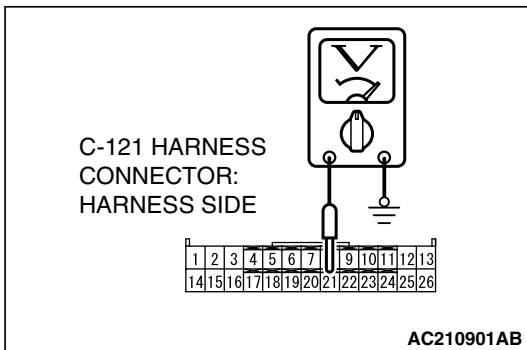
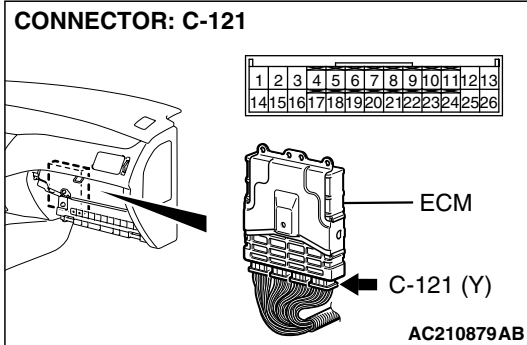

STEP 4. Measure the output circuit voltage at ECM connector C-121 terminal 21 by backprobing.

- (1) Do not disconnect ECM connector C-121.
- (2) Start the engine and allow it to idle.
- (3) Turn the A/C switch to the "ON" position.

- (4) Measure the voltage between terminal number 21 and ground by backprobing.
 - The voltage should measure 0.7 volt or more when the cooling fan is operating.

Q: Is the voltage 0.7 volt or more when the cooling fan is operating?

- YES :** Go to Step 6.
NO : Go to Step 5.

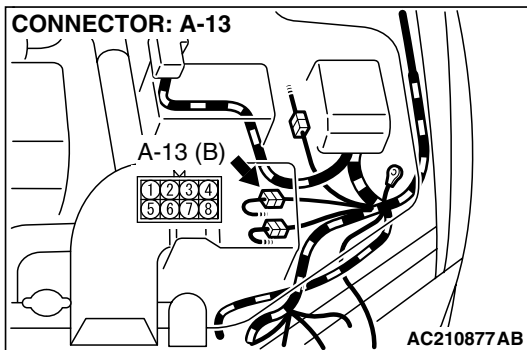

STEP 5. Check the harness wire between ECM connector C-121 and fan control module connector A-17.

NOTE: If intermediate connector A-13 terminal 2 is damaged, repair or replace it. Refer to GROUP 00E, Harness Connector Inspection P.00E-2.

CONNECTOR: C-121

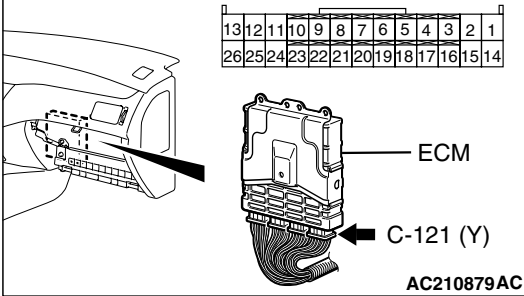

Q: Are the harness wires between ECM connector C-121 terminal 21 and fan control module connector A-17 terminal 2 damaged?

- YES :** Repair or replace them, then go to Step 8.
NO : Go to Step 6.

CONNECTOR: A-17

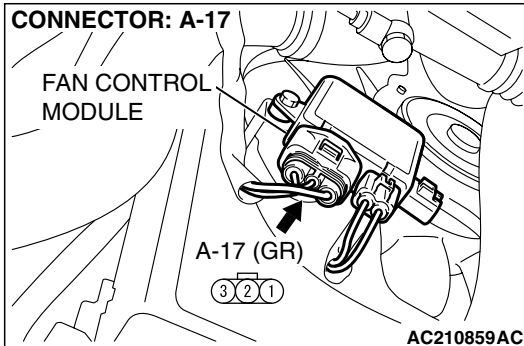

STEP 6. Check the fan control module at ECM connector C-121.

- (1) Do not disconnect ECM connector C-121.
- (2) Pull out terminal number 21.
- (3) Turn the ignition switch to the "ON" position.

Q: Does the cooling fan motor operate?

- YES :** Replace the ECM. Then go to Step 8.
NO : Go to Step 7.

CONNECTOR: C-121

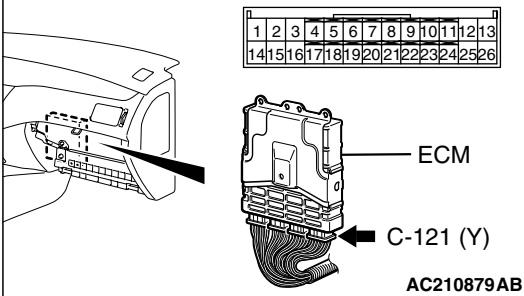

STEP 7. Check the fan control module at ECM connector C-121.

- (1) Disconnect ECM connector C-121.
- (2) Pull out terminal number 21.
- (3) Connect terminal number 21 to the body ground.
- (4) Turn the ignition switch to the "ON" position.

Q: Does the cooling fan motor stop running?

- YES :** Replace the ECM. Then go to Step 8.
NO : Replace the fan control module. Then go to Step 8.

CONNECTOR: C-121

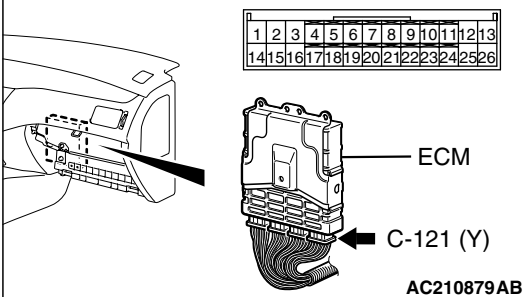

STEP 8. Check the symptoms.**Q: Does the cooling fan operate correctly?****YES** : The procedure is complete.**NO** : Return to Step 1.**ON-VEHICLE SERVICE****ENGINE COOLANT LEAK CHECK**

M1141001000269

⚠ WARNING

When pressure testing the cooling system, slowly release cooling system pressure to avoid getting burned by hot coolant.

⚠ CAUTION

- Be sure to completely clean away any moisture from the places checked.
- When the tester is taken out, be careful not to spill any coolant.
- Be careful when installing and removing the tester and when testing not to deform the filler neck of the radiator.

1. Check that the coolant level is up to the filler neck. Install a radiator tester and apply 160 kPa (23 psi) pressure, and then check for leakage from the radiator hose or connections.
2. If there is leakage, repair or replace the appropriate part.

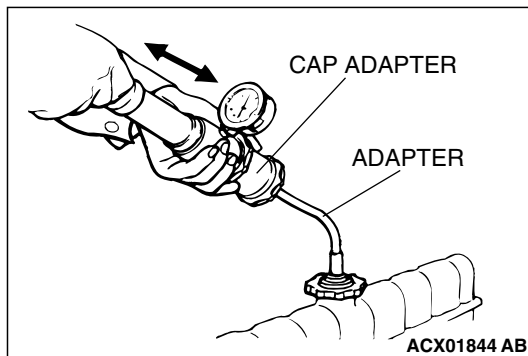
**RADIATOR CAP PRESSURE CHECK**

M1141001300334

NOTE: Be sure that the cap is clean before testing. Rust or other foreign material on the cap seal will cause an improper reading.

1. Use a cap adapter to attach the cap to the tester.
2. Increase the pressure until the indicator of the gauge stops moving.

Minimum limit: 83 kPa (12 psi)**Standard value: 93 – 123 kPa (14 – 18 psi)**

3. Replace the radiator cap if the reading does not remain at or above the minimum limit.

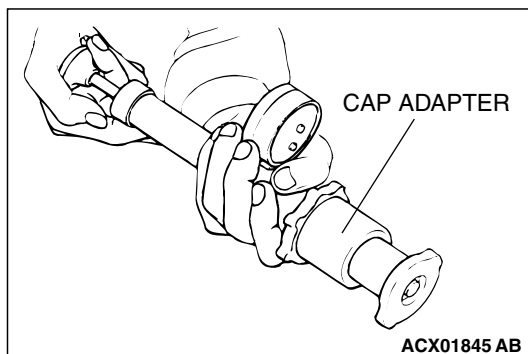

ENGINE COOLANT REPLACEMENT

M1141001200649

Required Special Tool:

- MB991871: LLC Changer

1. Remove the under cover (Refer to GROUP 51, Front Bumper P.51-2).

⚠ WARNING

When removing the radiator cap, use care to avoid contact with hot coolant or steam. Place a shop towel over the cap and turn the cap counterclockwise a little to let the pressure escape through the vinyl tube. After relieving the steam pressure, remove the cap by slowly turning it counterclockwise.

2. Drain the water from the radiator, heater core and engine after unplugging the radiator drain plug and removing the radiator cap.
3. Drain the water in the water jacket by unplugging the drain plug of the cylinder block.
4. Remove the reserve tank and drain the coolant.
5. Drain the cooling water then clean the path of the cooling water by injecting water into the radiator from the radiator cap area.
6. Apply the designated sealant to the screw area of the cylinder block drain plug, and then tighten to the standard torque.

Specified sealant: 3M™ AAD Part No. 8731 or equivalent

Tightening torque: 44 ± 5 N·m (33 ± 3 ft·lb)

7. Securely tighten the drain plug of the radiator.
8. Assemble the reserve tank.

⚠ CAUTION

Do not use alcohol or methanol anti-freeze or any engine coolants mixed with alcohol or methanol anti-freeze. The use of an improper anti-freeze can cause corrosion of the aluminum components.

9. By referring to the section on coolant, select an appropriate concentration for safe operating temperature within the range of 30 to 60%. Use special tool MB991871 to refill the coolant. A convenient mixture is a 50% water and 50% antifreeze solution [freezing point: -31°C (-32.8°F)].

Recommended antifreeze: Long Life Antifreeze Coolant or an equivalent

Quantity: 6.0 dm^3 (6.3 quarts)

NOTE: For how to use special tool MB991871, refer to its manufacturer's instructions.

10. Reinstall the radiator cap.
11. Start the engine and let it warm up until the thermostat opens.

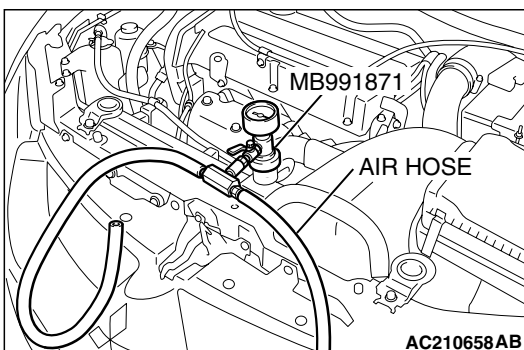
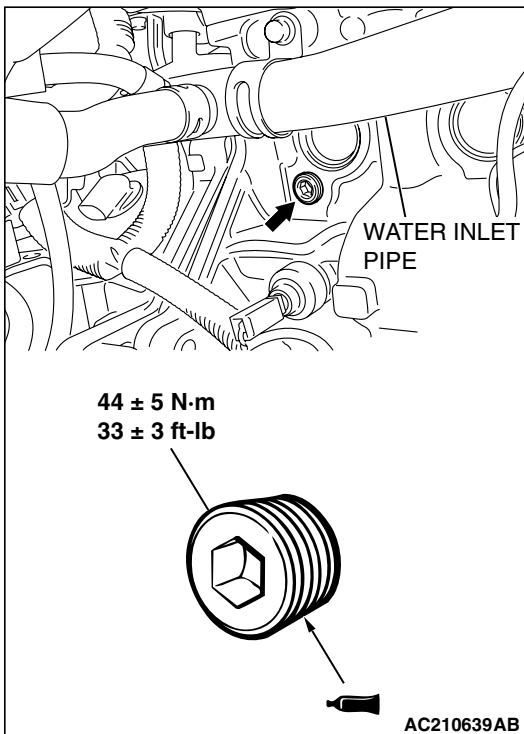

12. Repeatedly revving the engine up to 3,000 r/min several times, then stop the engine.
13. Remove the radiator cap after the engine has become cold, and pour in coolant up to the brim. Reinstall the cap.

⚠ CAUTION

Do not overfill the reserve tank.

14. Add coolant to the reserve tank between the "FULL" and "LOW" mark if necessary.
15. Install the under cover (Refer to GROUP 51, Front Bumper P.51-2).

ENGINE COOLANT CONCENTRATION TEST

M1141001100318

Refer to GROUP 00, Recommended Lubricants and Lubricant Capacities Table P.00-35.

FAN CONTROL MODULE CHECK

M1141006100205

Required Special Tool:

- MB991222: Probe

1. Remove the center under cover (Refer to GROUP 51, Front Bumper P.51-2).
2. Disconnect the fan control module connector.
3. Turn the ignition switch to the "ON" position, and measure the voltage between the harness-side connector terminals.
Standard value: Battery positive voltage
4. Turn the ignition switch to the "LOCK" (OFF) position, and connect the fan control module connector.

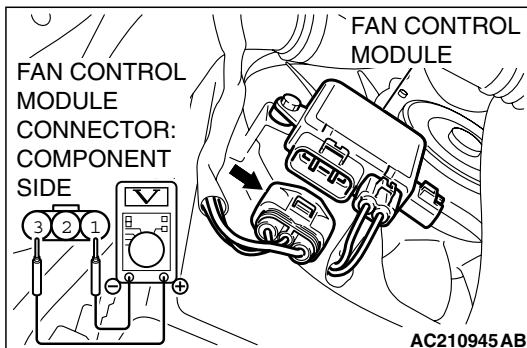

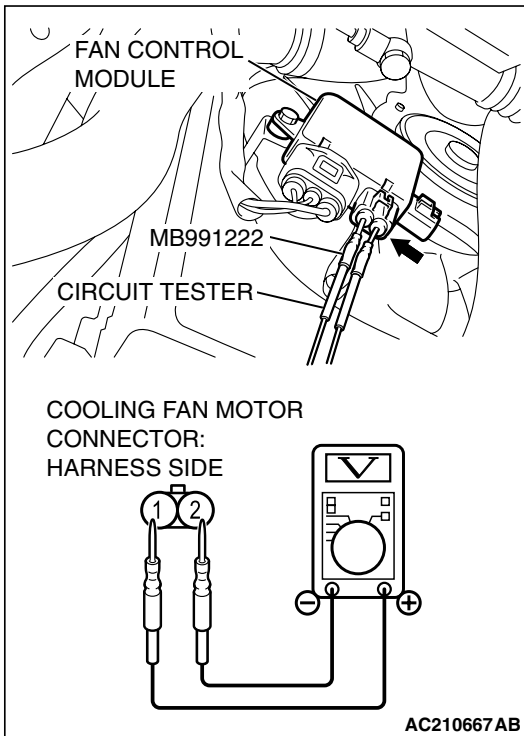

5. Insert special tool MB991222 at the back of the cooling fan motor connector.
6. Connect special tool MB991222 to the circuit tester.
7. Ensure that the A/C switch is off, and start the engine and run it at idle.
8. Measure the voltage between the cooling fan motor connector terminals.
Standard value: 1V or less
9. Turn the A/C switch to the "ON" position.

⚠ WARNING

Stay clear of the fan when the fan starts running.

10. Measure the voltage between the cooling fan motor connector terminals while the fan is running. The voltage should repeat the values 1) and 2) below.
Standard value:
1) $8.2 \pm 2.6 \text{ V}$
2) **Battery positive voltage $\pm 2.6 \text{ V}$**
11. If the voltage does not repeatedly change as indicated, replace the fan control module.
12. Install the center under cover (Refer to GROUP 51, Front Bumper P.51-2).

FAN CONTROL RELAY CONTINUITY CHECK

M1141006200235

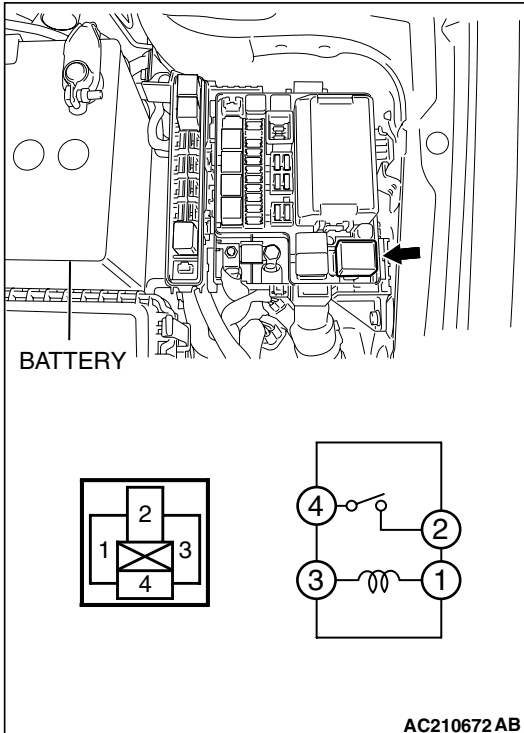

BATTERY VOLTAGE	TERMINAL NO. TO BE CONNECTED TO TESTER	CONTINUITY TEST RESULTS
Not applied	4 – 2	Open circuit
<ul style="list-style-type: none"> • Connect terminal No.1 and battery (+) terminal. • Connect terminal No.3 and battery (–) terminal. 	4 – 2	Less than 2 ohms

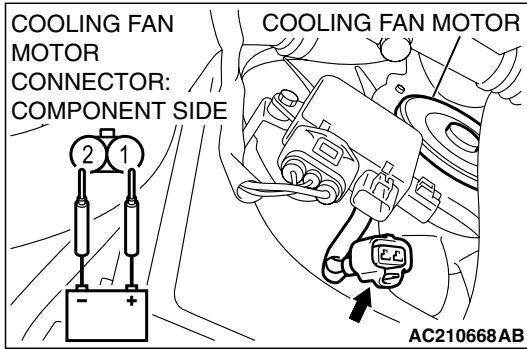

M1141007100037

COOLING FAN MOTOR CHECK

1. Remove the center under cover (Refer to GROUP 51, Front Bumper P.51-2).
2. Remove the cooling fan motor connector.

⚠ WARNING***Stay clear of the fan when the fan starts running.***

3. Check to see that the fan motor of the radiator turns when applying battery power between the connector terminals of the cooling fan motor. Also check to see that there is no abnormal sound coming from the cooling fan motor at this time.
4. If the cooling fan motor is defective, replace it.
5. Install the center under cover (Refer to GROUP 51, Front Bumper P.51-2).

RADIATOR

REMOVAL AND INSTALLATION

M1141001500402

Pre-removal Operation

- Under Cover Removal (Refer to GROUP 51, Front Bumper P.51-2).
- Engine Coolant Draining (Refer to P.14-19).
- Battery and Battery Tray Removal
- Air Cleaner Assembly Removal (Refer to GROUP 15, Air Cleaner P.15-7).
- Air Hose E, Air Pipe C and Air Hose D Removal (Refer to GROUP 15, Charge Air Cooler P.15-8).

Post-installation Operation

- Air Hose E, Air Pipe C and Air Hose D Installation (Refer to GROUP 15, Charge Air Cooler P.15-8).
- Air Cleaner Assembly Installation (Refer to GROUP 15, Air Cleaner P.15-7).
- Battery and Battery Tray Installation
- Engine Coolant Refilling (Refer to P.14-19).
- Under Cover Installation (Refer to GROUP 51, Front Bumper P.51-2).

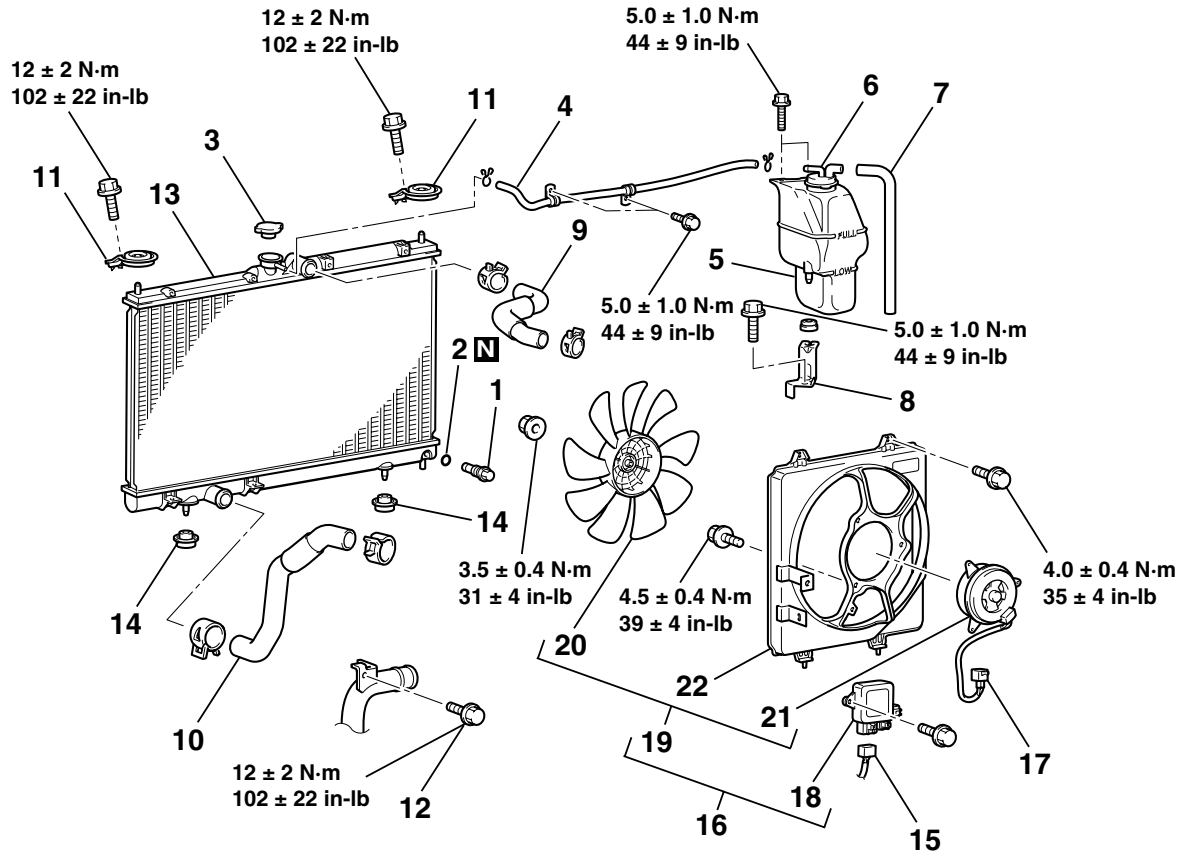

RADIATOR REMOVAL STEPS

1. RADIATOR DRAIN PLUG
2. O-RING
3. RADIATOR CAP
4. RESERVE TANK HOSE
5. RESERVE TANK
6. RESERVE TANK CAP
7. RESERVE TANK HOSE
8. RESERVE TANK BRACKET
9. RADIATOR UPPER HOSE
10. RADIATOR LOWER HOSE
11. UPPER INSULATOR
12. AIR PIPE B MOUNTING BOLT
13. RADIATOR ASSEMBLY
14. LOWER INSULATOR

AC210706AB

RADIATOR REMOVAL STEPS

15. FAN CONTROL MODULE CONNECTOR
16. FAN CONTROL MODULE, COOLING FAN MOTOR, FAN AND SHROUD ASSEMBLY
17. COOLING FAN MOTOR CONNECTOR
18. FAN CONTROL MODULE
19. COOLING FAN MOTOR, FAN AND SHROUD ASSEMBLY
20. COOLING FAN

<<A>> >>A<<
<<A>> >>A<<
<>

<>

**FAN CONTROL MODULE AND
COOLING FAN MOTOR
REMOVAL STEPS (Continued)**

21. COOLING FAN MOTOR
22. COOLING FAN SHROUD

REMOVAL SERVICE POINTS

**<<A>> RADIATOR UPPER HOSE/RADIATOR
LOWER HOSE DISCONNECTION**

Make mating marks on the radiator hose and the hose clamp. Disconnect the radiator hose.

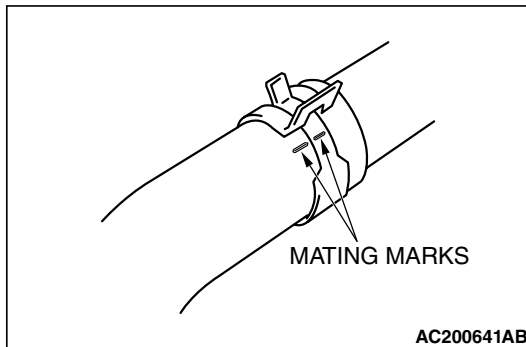

<> AIR PIPE B MOUNTING BOLT REMOVAL

After removing the bolt, position air pipe B out of the way so that the pipe does not interfere with the radiator assembly or the cooling fan motor, the fan and shroud assembly.

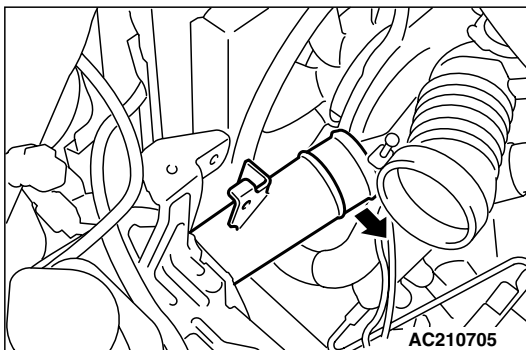

INSTALLATION SERVICE POINT

**>>A<< RADIATOR LOWER HOSE/RADIATOR
UPPER HOSE CONNECTION**

1. Insert each hose as far as the projection of the water inlet pipe, water outlet fitting or radiator.
2. Align the mating marks on the radiator hose and hose clamp, and then connect the radiator hose.

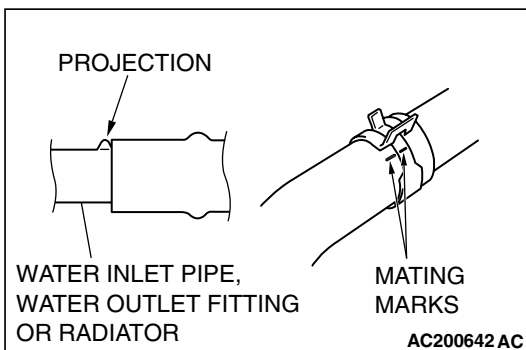

THERMOSTAT

REMOVAL AND INSTALLATION

M1141002400356

Pre-removal Operation

- Under Cover Removal (Refer to GROUP 51, Front Bumper P.51-2).
- Engine Coolant Draining (Refer to P.14-19).
- Intake Air Duct Removal (Refer to GROUP 15, Air Cleaner P.15-7).
- Air Hose E, Air Pipe C and Air Hose D Removal (Refer to GROUP 15, Charge Air Cooler P.15-8).

Post-installation Operation

- Air Hose E, Air Pipe C and Air Hose D Installation (Refer to GROUP 15, Charge Air Cooler P.15-8).
- Intake Air Duct Installation (Refer to GROUP 15, Air Cleaner P.15-7).
- Engine Coolant Refilling (Refer to P.14-19).
- Under Cover Installation (Refer to GROUP 51, Front Bumper P.51-2).

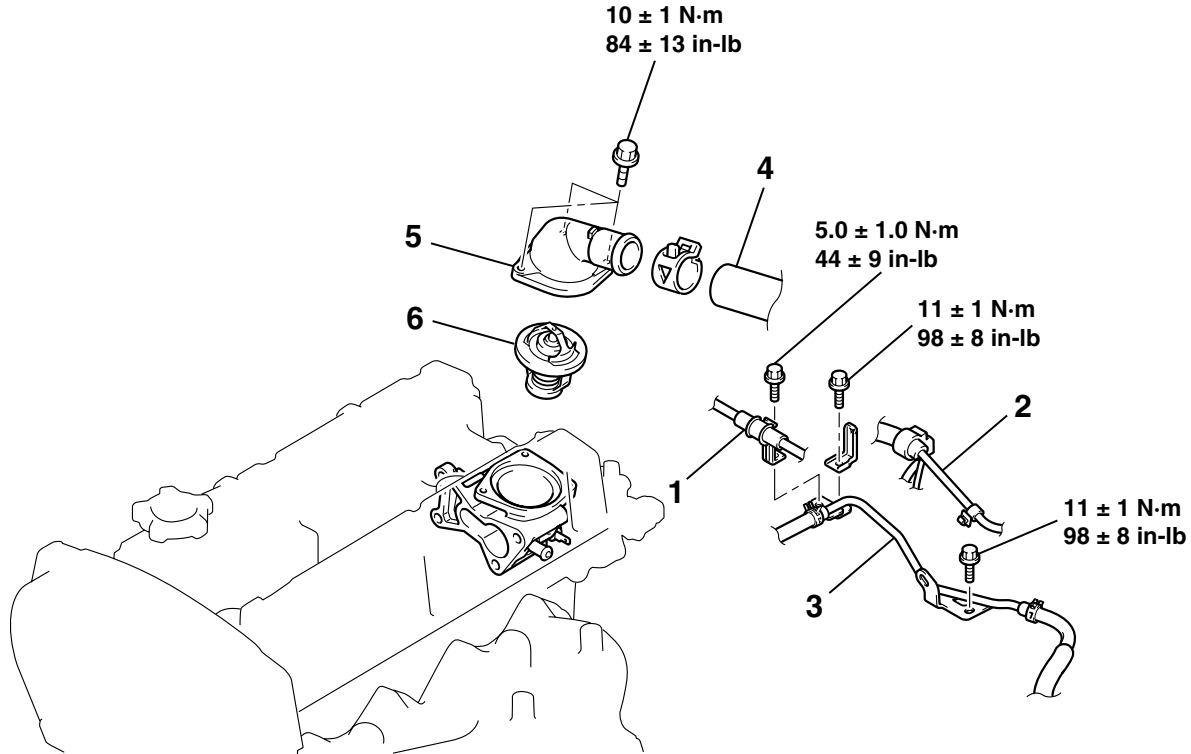

AC210739AB

REMOVAL STEPS

1. ACCELERATOR CABLE CONNECTION
2. CONTROL WIRING HARNESS CONNECTION
3. VACUUM HOSE AND PIPE ASSEMBLY

REMOVAL STEPS (Continued)

- | | | |
|-------|-------|-----------------------------------|
| <<A>> | >>C<< | 4. RADIATOR UPPER HOSE CONNECTION |
| | >>B<< | 5. WATER OUTLET FITTING |
| | >>A<< | 6. THERMOSTAT |

REMOVAL SERVICE POINT

<<A>> RADIATOR UPPER HOSE DISCONNECTION

Make mating marks on the radiator hose and the hose clamp. Disconnect the radiator hose.

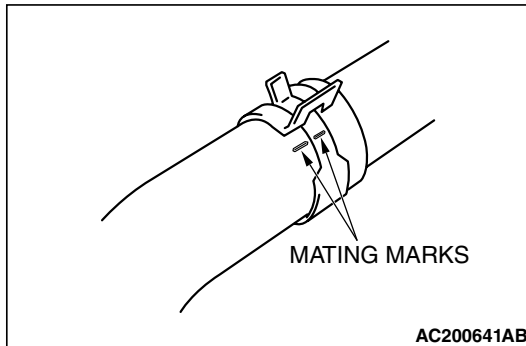

INSTALLATION SERVICE POINTS

>>A<< THERMOSTAT INSTALLATION

⚠ CAUTION

Make absolutely sure that no oil is adhering to the rubber ring of the thermostat. In addition, be careful not to fold over or scratch the rubber ring when inserting. If the rubber ring is damaged, replace the thermostat.

Install the thermostat being careful not to fold over or scratch the rubber ring.

>>B<< WATER OUTLET FITTING INSTALLATION

1. Remove sealant from the water outlet fitting and cylinder head surfaces.
2. Apply a bead of the sealant to the cylinder head mating surface of the water outlet fitting as shown.

Specified sealant: 3M™ AAD Part No. 8672, 3M™ AAD Part No. 8679/8678 or equivalent

NOTE: Install the water outlet fitting within 15 minutes after applying liquid gasket.

3. Install the water outlet fitting to the cylinder head.

⚠ CAUTION

Then wait at least one hour. Never start the engine or let engine oil or coolant touch the adhesion surface during that time.

4. Tighten the water outlet fitting mounting bolts to the specified torque.

Tightening torque: 10 ± 1 N·m (84 ± 13 in-lb)

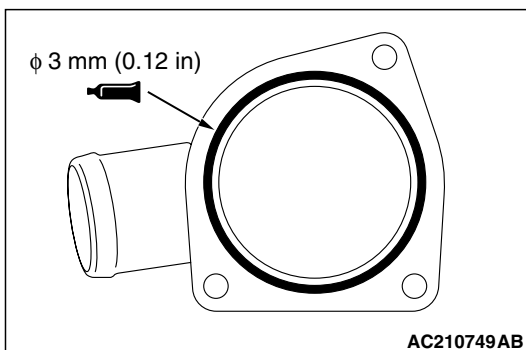

>>C<< RADIATOR UPPER HOSE CONNECTION

1. Insert each hose as far as the projection of the water outlet fitting.
2. Align the mating marks on the radiator hose and hose clamp, and then connect the radiator hose.

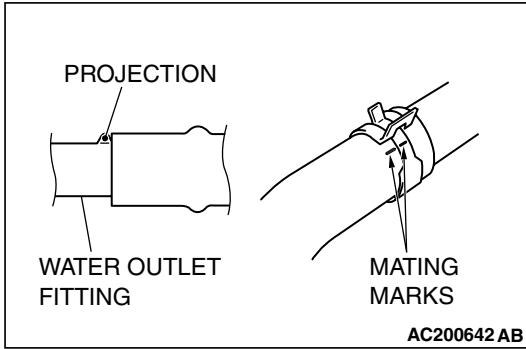

INSPECTION

M1141002500342

THERMOSTAT CHECK

1. Immerse the thermostat in water, and heat the water while stirring. Check the thermostat valve opening temperature.

Standard value: Valve opening temperature: $80 \pm 1.5^{\circ}\text{C}$ ($176 \pm 3^{\circ}\text{F}$)

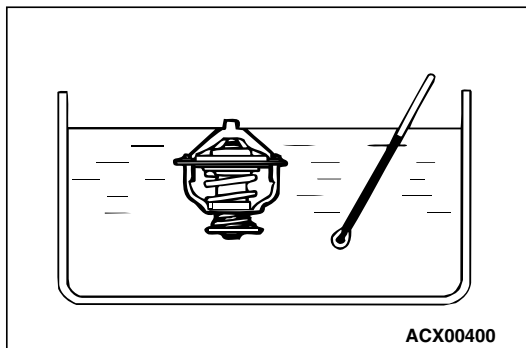

2. Check that the amount of valve lift is at the standard value when the water is at the full-opening temperature.

NOTE: Measure the valve height when the thermostat is fully closed, and use this measurement to compare the valve height when the thermostat is fully open.

Standard value:

Full-opening temperature: 93°C (199°F)

Amount of valve lift: 9.5 mm (0.37 inch) or more

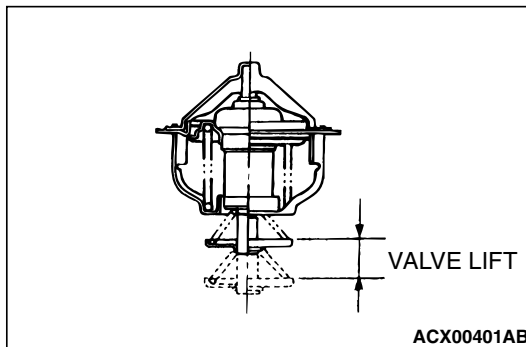

WATER PUMP

REMOVAL AND INSTALLATION

M1141002700379

CAUTION

If the vehicle is equipped with the Brembo™ disc brake, during maintenance, take care not to contact the caliper with tools or parts, because the caliper paint will be scratched.

<p>Pre-removal Operation</p> <ul style="list-style-type: none"> • Under Cover Removal (Refer to GROUP 51, Front Bumper P.51-2). • Engine Coolant Draining (Refer to P.14-19). • Timing Belt Tensioner Adjuster Removal (Refer to GROUP 11A, Timing Belt P.11A-48). 	<p>Post-installation Operation</p> <ul style="list-style-type: none"> • Timing Tensioner Adjuster Belt Installation (Refer to GROUP 11A, Timing Belt P.11A-48). • Engine Coolant Refilling (Refer to P.14-19). • Under Cover Installation (Refer to GROUP 51, Front Bumper P.51-2).
--	---

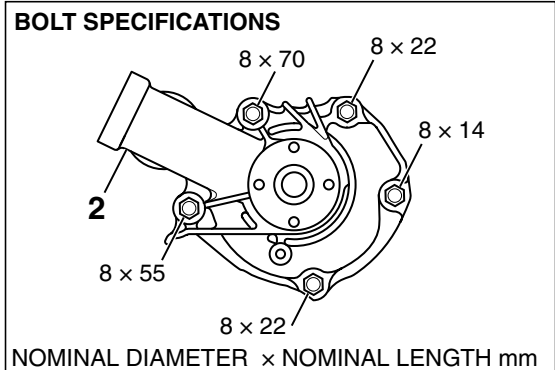
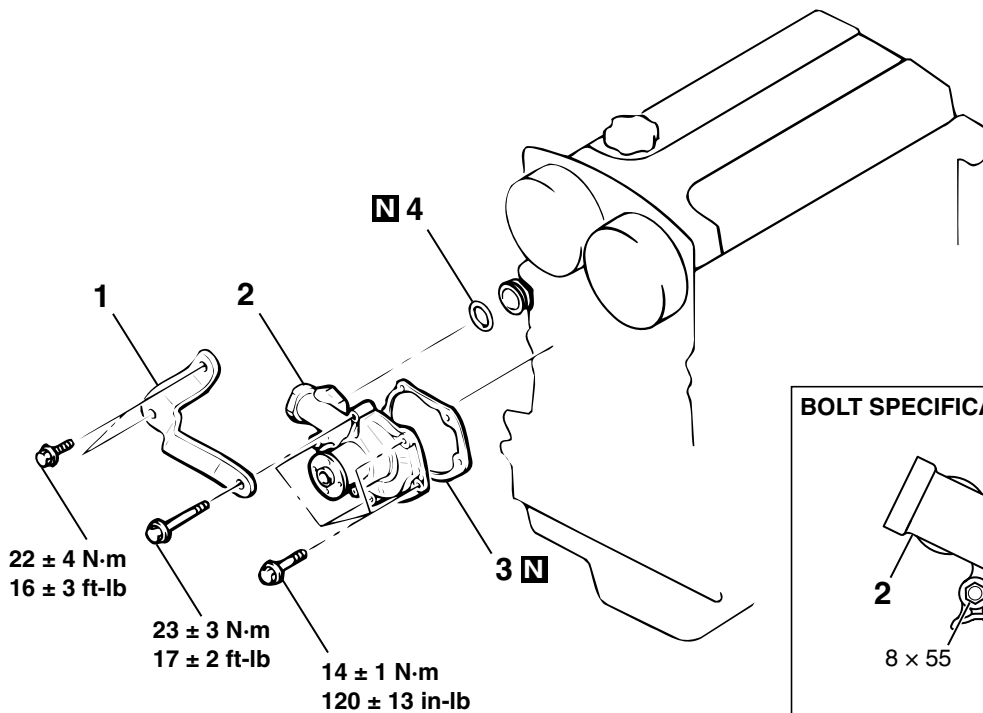

AC202463 AC

REMOVAL STEPS

1. GENERATOR BRACE
2. WATER PUMP

REMOVAL STEPS (Continued)

3. WATER PUMP GASKET
4. O-RING

INSTALLATION SERVICE POINT

>>A<< O-RING INSTALLATION

⚠ CAUTION

Do not let the O-ring get contaminated with grease or engine oil.

Fit an O-ring into the O-ring groove located at the end of the water inlet pipe and apply water to the O-ring or the inside of the mounting surface of the water pump for insertion.

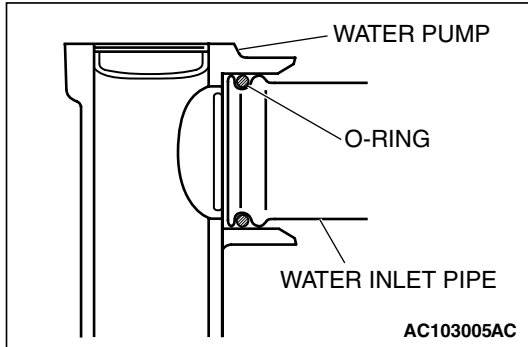

WATER HOSE AND WATER PIPE

REMOVAL AND INSTALLATION

M1141003300363

Pre-removal Operation

- Under Cover Removal (Refer to GROUP 51, Front Bumper P.51-2).
- Engine Coolant Draining (Refer to P.14-19).
- Battery and Battery Tray Removal
- Air Cleaner Assembly Removal (Refer to GROUP 15, Air Cleaner P.15-7).
- Turbocharger Bypass Valve Assembly, Air By-pass Hose, Air Hose E, Air Pipe C and Air Hose D Removal (Refer to GROUP 15, Charge Air Cooler P.15-8).

Post-installation Operation

- Turbocharger Bypass Valve Assembly, Air By-pass Hose, Air Hose E, Air Pipe C and Air Hose D Installation (Refer to GROUP 15, Charge Air Cooler P.15-8).
- Air Cleaner Assembly Installation (Refer to GROUP 15, Air Cleaner P.15-7).
- Battery and Battery Tray Installation
- Engine Coolant Refilling (Refer to P.14-19).
- Under Cover Installation (Refer to GROUP 51, Front Bumper P.51-2).

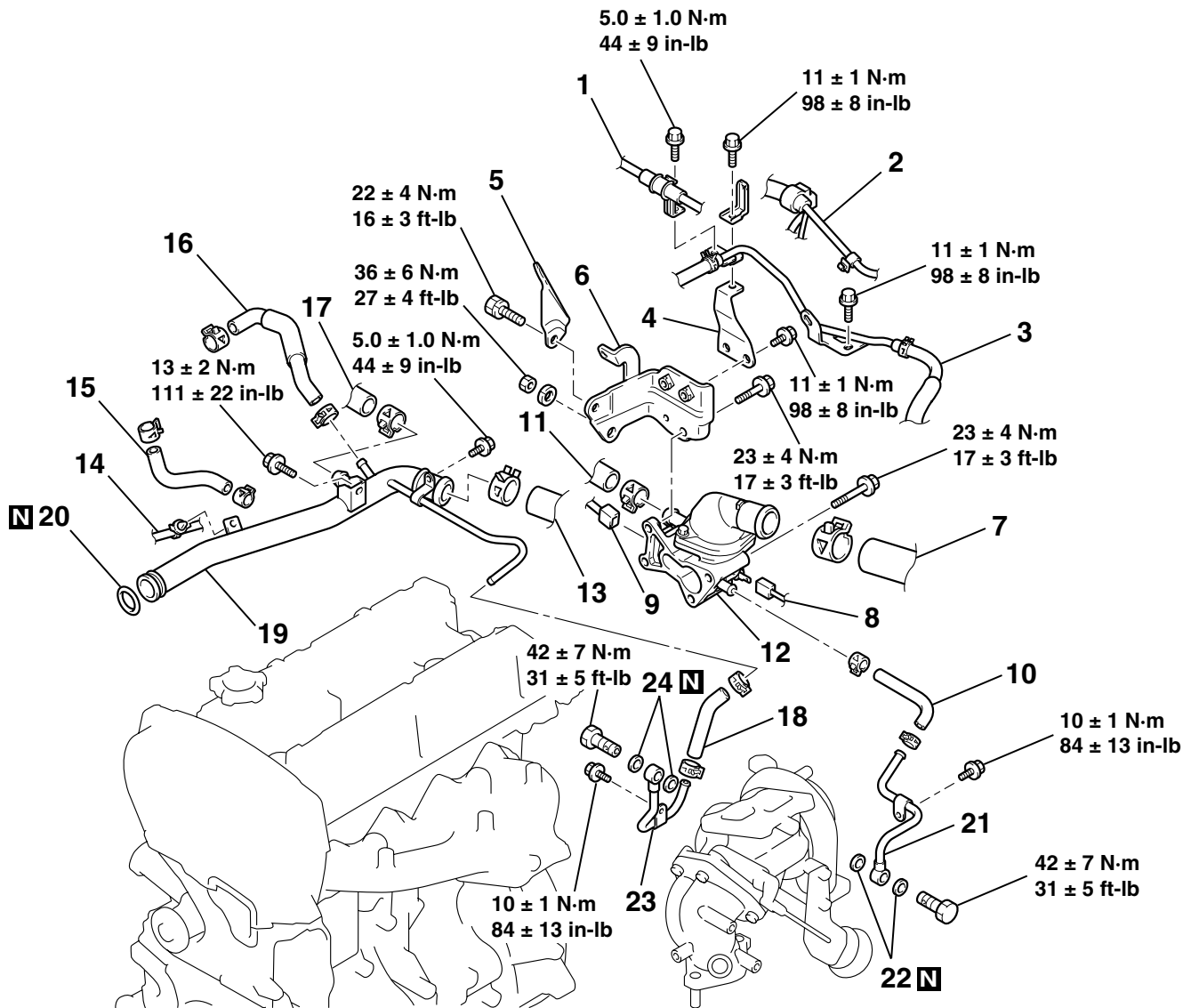

AC210740AB

REMOVAL STEPS

1. ACCELERATOR CABLE CONNECTION
2. CONTROL WIRING HARNESS CONNECTION

REMOVAL STEPS (Continued)

3. VACUUM HOSE AND PIPE ASSEMBLY
4. VACUUM PIPE BRACKET
5. ENGINE HANGER

REMOVAL STEPS (Continued)

- 6. BRACKET
- <<A>> >>C<< 7. RADIATOR UPPER HOSE CONNECTION
- 8. ENGINE COOLANT TEMPERATURE GAUGE UNIT CONNECTOR
- 9. ENGINE COOLANT TEMPERATURE SENSOR CONNECTOR
- 10. WATER FEED HOSE
- 11. HEATER HOSE CONNECTION
- >>D<< 12. WATER OUTLET FITTING AND THERMOSTAT CASE ASSEMBLY
- <<A>> >>C<< 13. RADIATOR LOWER HOSE CONNECTION
- 14. KNOCK SENSOR CONNECTION
- 15. WATER FEED HOSE
- 16. WATER RETURN HOSE
- 17. HEATER HOSE CONNECTION
- 18. WATER RETURN HOSE
- >>B<< 19. WATER INLET PIPE
- >>A<< 20. O-RING
- 21. TURBOCHARGER WATER FEED PIPE
- 22. GASKETS
 - TURBOCHARGER AND EXHAUST FITTING ASSEMBLY (REFER TO GROUP 15, EXHAUST MANIFOLD AND TURBOCHARGER [P.15-12](#)).
- 23. TURBOCHARGER WATER RETURN PIPE
- 24. GASKETS

REMOVAL SERVICE POINT

<<A>> RADIATOR UPPER HOSE/RADIATOR LOWER HOSE DISCONNECTION

Make mating marks on the radiator hose and the hose clamp. Disconnect the radiator hose.

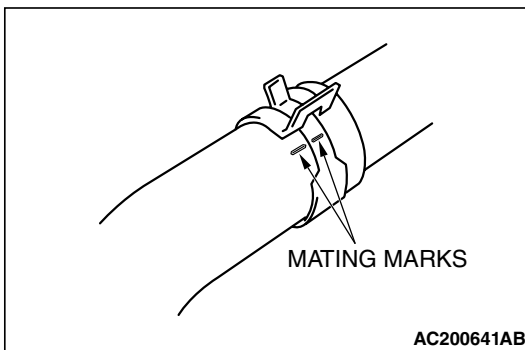

INSTALLATION SERVICE POINTS**>>A<< O-RING INSTALLATION****⚠ CAUTION**

Do not let the O-ring get contaminated with grease or engine oil.

Fit an O-ring into the groove of the water inlet pipe and apply water to the circumference of the O-ring or the inside of the mounting surface of the pipe for insertion.

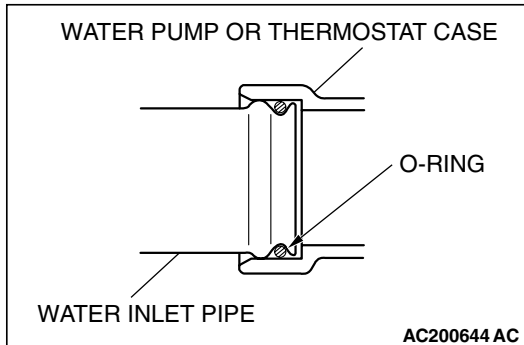
**>>B<< WATER INLET PIPE INSTALLATION**

After installing the water outlet fitting and thermostat case assembly, tighten the mounting bolt of the water inlet pipe to the specified torque.

Tightening torque

M6: 5.0 ± 1.0 N·m (44 ± 9 in-lb)

M8: 13 ± 2 N·m (111 ± 22 in-lb)

>>C<< RADIATOR LOWER HOSE/RADIATOR UPPER HOSE CONNECTION

1. Insert each hose as far as the projection of the water inlet pipe or water outlet fitting.
2. Align the mating marks on the radiator hose and hose clamp, and then connect the radiator hose.

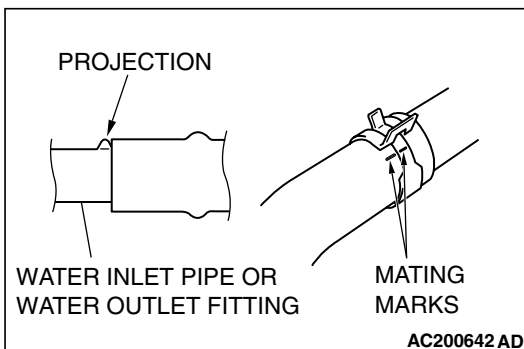
**>>D<< WATER OUTLET FITTING AND THERMOSTAT CASE ASSEMBLY INSTALLATION**

1. Remove sealant from the thermostat case and cylinder head surfaces.

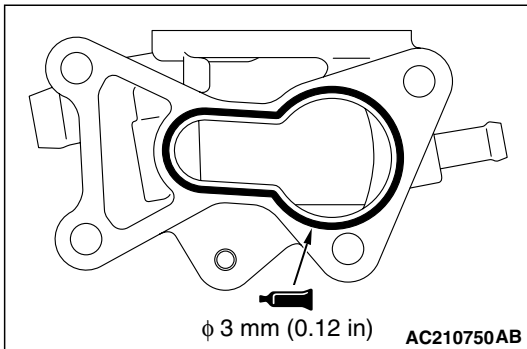

2. Apply a bead of the sealant to the cylinder head mating surface of the thermostat case as shown.

Specified sealant: 3M™ AAD Part No. 8672, 3M™ AAD Part No. 8679/8678 or equivalent

NOTE: Install the water outlet fitting and thermostat case assembly within 15 minutes after applying liquid gasket.

3. Install the water outlet fitting and thermostat case assembly to the cylinder head.

⚠ CAUTION

Then wait at least one hour. Never start the engine or let engine oil or coolant touch the adhesion surface during that time.

4. Tighten the thermostat case mounting bolts to the specified torque.

Tightening torque: 23 ± 4 N·m (17 ± 3 ft-lb)

INSPECTION

M1141003400252

WATER PIPE AND HOSE CHECK

Check the water pipe and hose for cracks, damage and clogs. Replace them if necessary.

SPECIFICATIONS**FASTENER TIGHTENING SPECIFICATIONS**

M1141005000261

ITEM		SPECIFICATION
Cylinder block		
Cylinder block drain plug		44 ± 5 N·m (33 ± 3 ft-lb)
Radiator		
Air Pipe B bolt		12 ± 2 N·m (102 ± 22 in-lb)
Cooling fan motor bolt		4.5 ± 0.4 N·m (39 ± 4 in-lb)
Cooling fan nut		3.5 ± 0.4 N·m (31 ± 4 in-lb)
Cooling fan shroud bolt		4.0 ± 0.4 N·m (35 ± 4 in-lb)
Reserve tank bolt		5.0 ± 1.0 N·m (44 ± 9 in-lb)
Reserve tank bracket bolt		5.0 ± 1.0 N·m (44 ± 9 in-lb)
Reserve tank hose bolt		5.0 ± 1.0 N·m (44 ± 9 in-lb)
Upper insulator bolt		12 ± 2 N·m (102 ± 22 in-lb)
Thermostat		
Accelerator cable bolt		5.0 ± 1.0 N·m (44 ± 9 in-lb)
Control harness bolt		11 ± 1 N·m (98 ± 8 in-lb)
Vacuum pipe bolt		11 ± 1 N·m (98 ± 8 in-lb)
Water outlet fitting bolt		10 ± 1 N·m (84 ± 13 in-lb)
Water hose and water pipe		
Accelerator cable bolt		5.0 ± 1.0 N·m (44 ± 9 in-lb)
Bracket bolt		36 ± 6 N·m (27 ± 4 ft-lb)
Control harness bolt		11 ± 1 N·m (98 ± 8 in-lb)
Engine hanger bolt		22 ± 4 N·m (16 ± 3 ft-lb)
Turbocharger water feed pipe bolt (bolt, eye)		42 ± 7 N·m (31 ± 5 ft-lb)
Turbocharger water feed pipe bolt (bolt, flange)		10 ± 1 N·m (84 ± 13 in-lb)
Turbocharger water return pipe bolt (bolt, eye)		42 ± 7 N·m (31 ± 5 ft-lb)
Turbocharger water return pipe bolt (bolt, flange)		10 ± 1 N·m (84 ± 13 in-lb)
Vacuum pipe bolt		11 ± 1 N·m (98 ± 8 in-lb)
Vacuum pipe bracket bolt		11 ± 1 N·m (98 ± 8 in-lb)
Water inlet pipe bolt	M6	5.0 ± 1.0 N·m (44 ± 9 in-lb)
	M8	13 ± 2 N·m (111 ± 22 in-lb)
Water outlet fitting and thermostat case bolt		23 ± 4 N·m (17 ± 3 ft-lb)
Water pump		
Generator brace bolt		22 ± 4 N·m (16 ± 3 ft-lb)
Water pump and generator brace bolt		23 ± 3 N·m (17 ± 2 ft-lb)
Water pump bolt		14 ± 1 N·m (120 ± 13 in-lb)

SERVICE SPECIFICATIONS

M1141000300342

ITEM		STANDARD VALUE	LIMIT
Valve opening pressure of radiator cap kPa (psi)		93 – 123 (14 – 18)	Minimum 83 (12)
Fan control module input voltage V	Ignition switch: "ON"	Battery positive voltage	-
Fan control module output voltage V	A/C switch: "OFF"	1 or less	-
	A/C switch: "ON"	Repeat steps 1) and 2). 1) 8.2 ± 2.6 2) Battery positive voltage ± 2.6	-
Thermostat	Valve opening temperature of thermostat °C (°F)	80 ± 1.5 (176 ± 3)	-
	Full-opening temperature of thermostat °C (°F)	93 (199)	-
	Valve lift mm (in)	9.5 (0.37) or more	-

COOLANT

M1141000400510

ITEM	QUANTITY dm ³ (qt)
Long Life Antifreeze Coolant or an equivalent	6.0 (6.3)

SEALANTS

M1141000500283

ITEM	SPECIFIED SEALANT
Cylinder block drain plug	3M™ AAD Part No. 8731 or equivalent
Thermostat case	3M™ AAD Part No. 8672, 3M™ AAD Part No. 8679/8678 or equivalent
Water outlet fitting	

NOTES