SECTION 51

EXTERIOR

CONTENTS

General	1	Rear bumper	4
Front bumper	2	Rear bumper	4
Front bumper	2	Markings	6

General

Servicing guidelines have been changed in conjunction with the changes or additions listed below.

Other servicing guidelines remain unchanged.

- Changes made to the shape and component of the front bumper.
- Changes made to the shape and component of the rear bumper.
- Changes made to the method for affixing the front 3-diamonds badge.
- Changes made to the position for affixing the LANCER badge and the EVOLUTION badge.

Front bumper

Front bumper

Removal and fitting

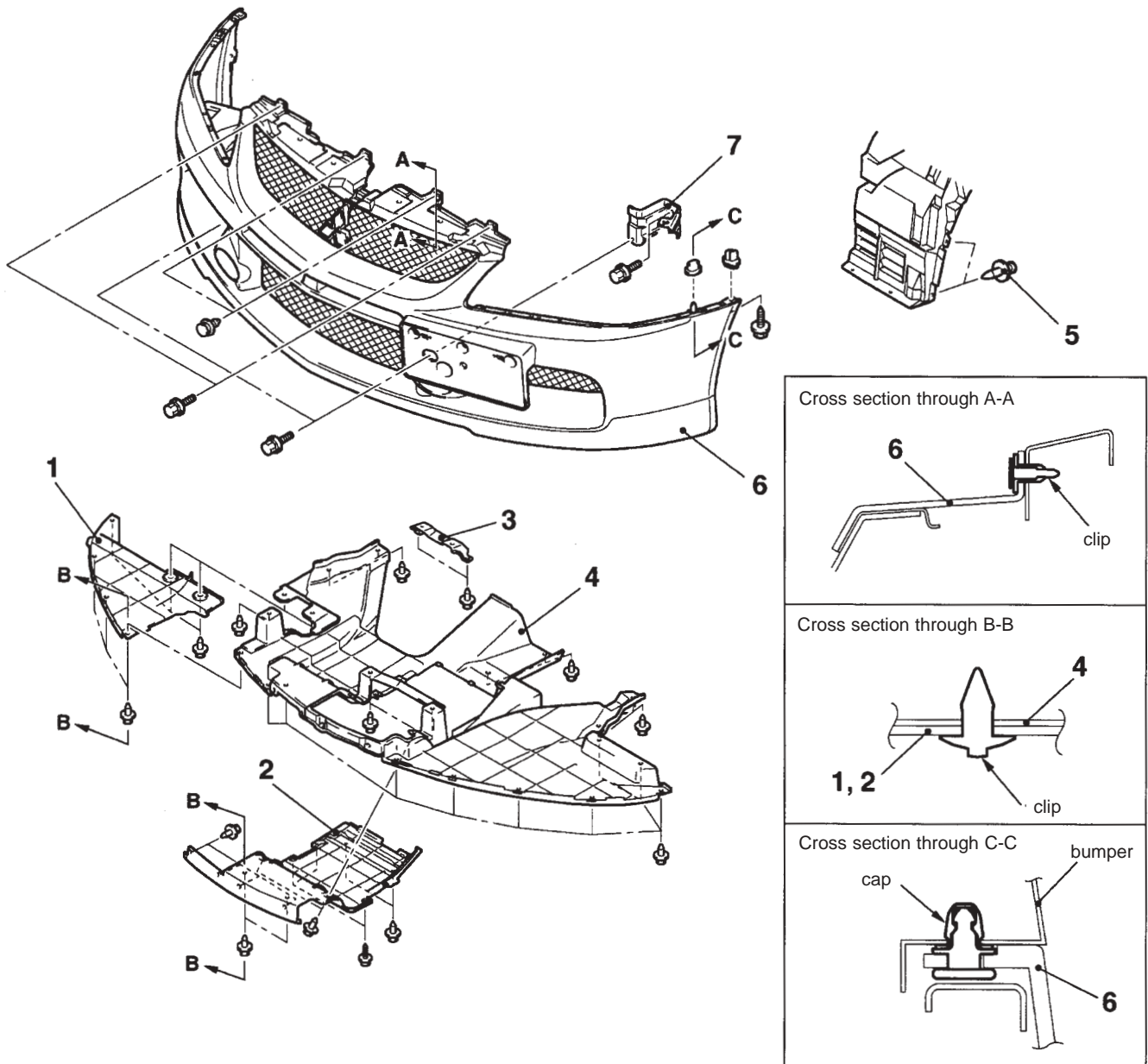
**Removal procedure**

1. Side valence
2. Centre valence
3. valence centre bracket
4. Front valence
5. Clip for attaching the splash shield

- Inter-cooler water spray hose connection (Ref Section 15)
- 6. Front bumper ASSY
- 7. Front bumper stay

AC407353AB

Dismantling and assembly

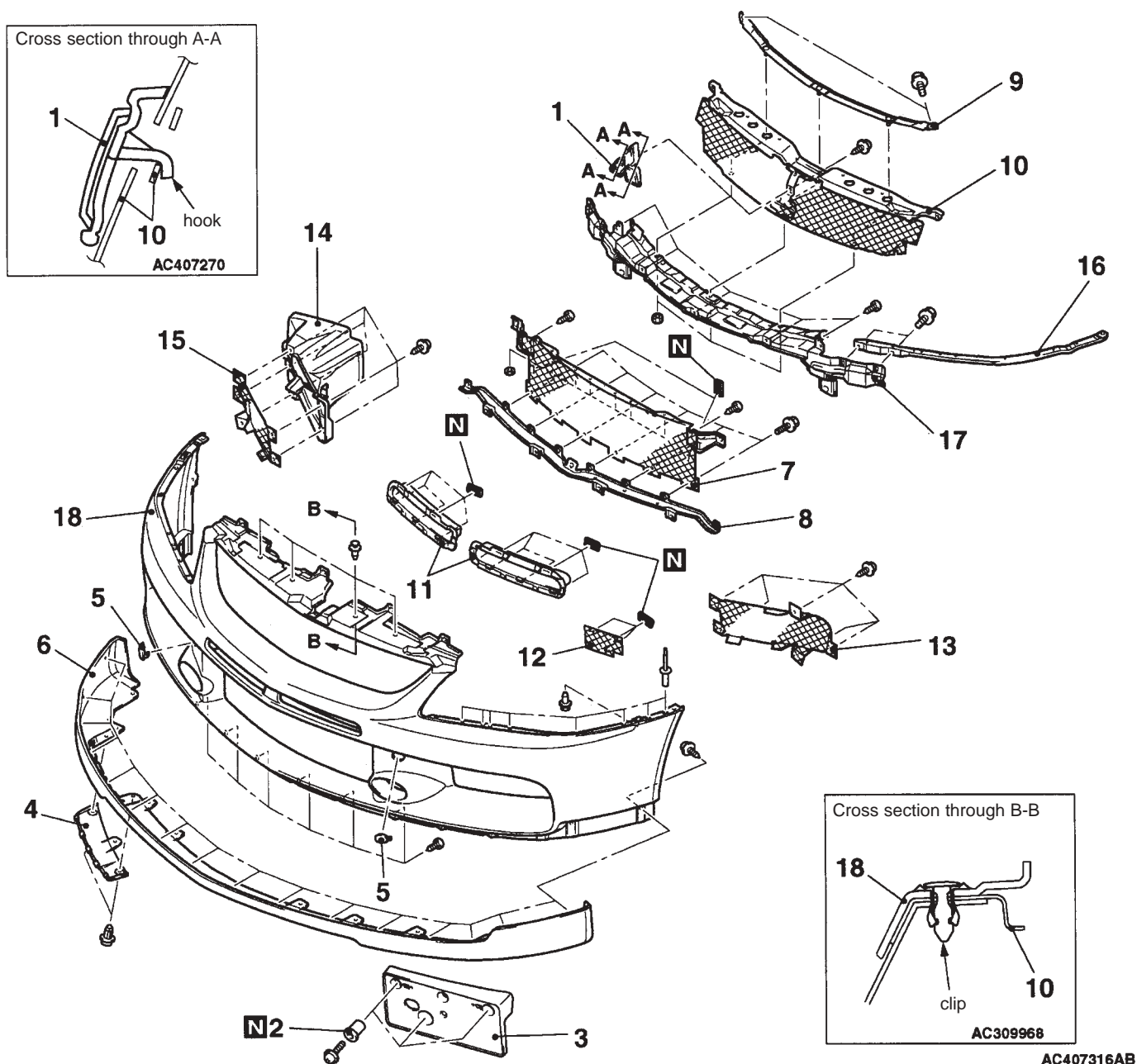

Dismantling procedure

- | | |
|---|--|
| <ol style="list-style-type: none"> 1. Front 3-diamonds badge 2. Front bumper nut 3. Front number plate garnish 4. Front bumper cover A 5. Front bumper cover B 6. Air dam skirt panel 7. Front bumper centre net 8. Front bumper lower plate 9. Front bumper upper plate 10. Front bumper upper support | <ol style="list-style-type: none"> 11. Air intake cover 12. Front bumper net 13. Bumper side net (LH) 14. Oil cooler duct 15. Bumper side net (RH) • Inter-cooler water spray hose and nozzle (Ref Section 15) 16. Front bumper side plate 17. Front bumper upper reinforcement 18. Front bumper facing |
|---|--|

Note:
The main points for dismantling and assembly remain unchanged.

Rear bumper

Jobs to be completed before removal and after fitting

- Removal and refitting of the rear combination lamp
- Removal and refitting of the rear end trim
- Removal and refitting of the boot area side trim lid

Rear bumper Removal and fitting

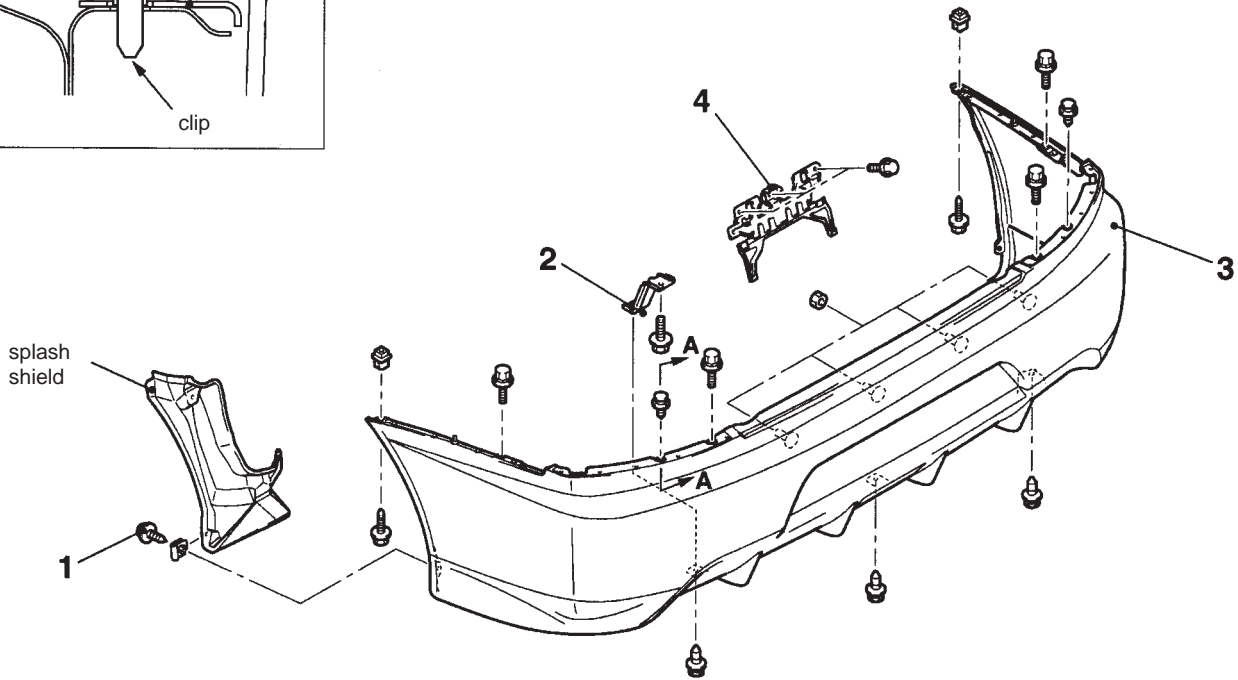
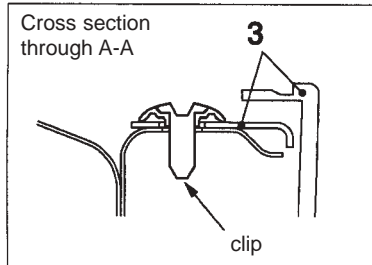

AC407319AB

Removal procedure

1. Screw for attaching the splash shield
2. Rear bumper bracket
3. Rear bumper ASSY
4. Rear bumper plate bracket

Dismantling and assembly

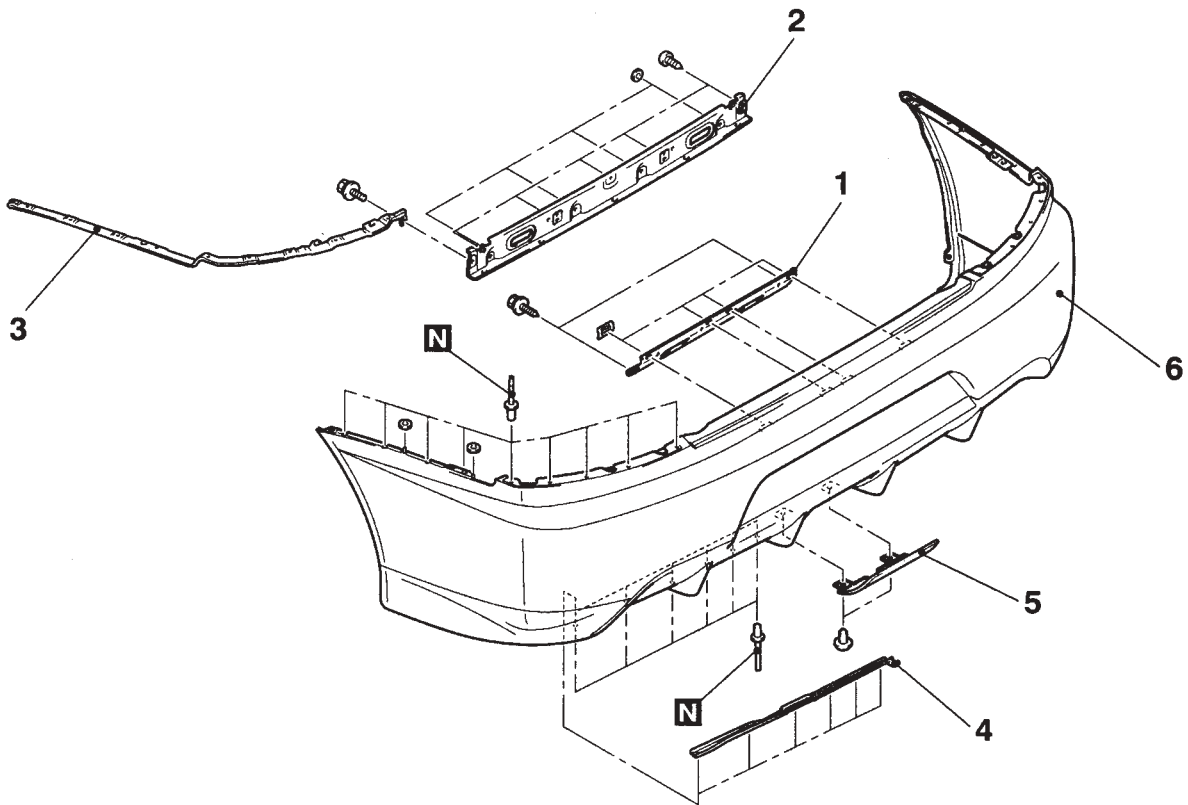

AC407263AB

Dismantling procedure

- | | |
|---|---|
| <p>◀ A ▶ ▶ A ◀</p> <p>1. Number plate lamp bracket
• Number plate lamp ASSY</p> | <p>◀ A ▶ ▶ A ◀</p> <p>4. Rear bumper facing support, side reinforcement</p> |
| <p>2. Rear bumper reinforcement</p> | <p>5. Rear bumper valence</p> |
| <p>3. Rear bumper side plate</p> | <p>6. Rear bumper facing</p> |

Note:
The main points for dismantling and assembly remain unchanged.

Markings

Removal and affixing

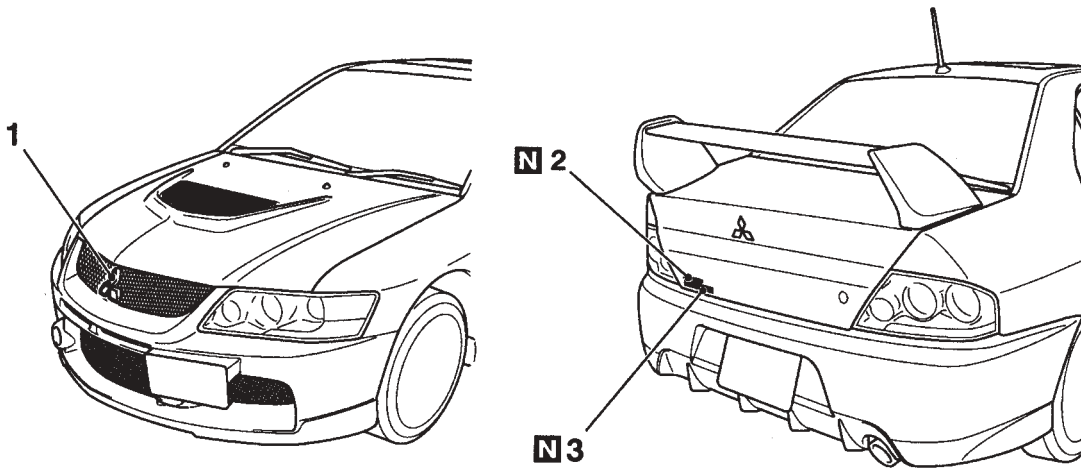

AC407268 AR

1. Front 3-diamonds badge (Ref P.51- 3)

▶ A ◀ 2. LANCER badge
▶ A ◀ 3. EVOLUTION badge

Guidelines for affixing markings

▶ A ◀ Affixing markings

1. Positioning

2. LANCER badge 3. EVOLUTION badge

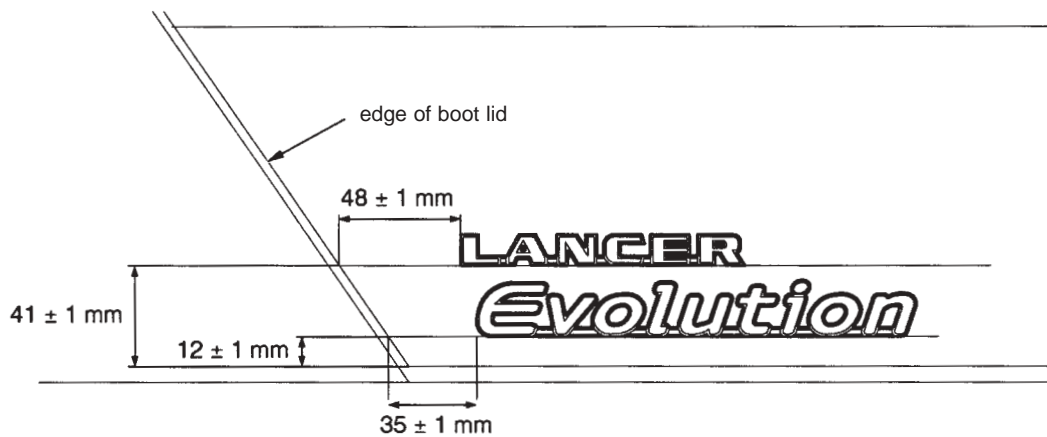

AC21

2. Guidelines for affixing

- (1) Using white spirit, remove any grease from the place where the badges will be affixed.
- (2) Remove the protective paper from the back of the badges, and affix them in the designated places.

Caution

- 1) Perform this job in an ambient temperature of 20~38°C, and in a dust free location.
- 2) If the job is being performed in an ambient temperature of less than 20°C, warm up the badges, and the area of the body onto which they will be affixed, to a temperature of 20~38°C.
- 3) Ensure that air bubbles are not trapped in the adhesive tape when the badges are affixed.